

Installation Manual

Passive Harmonic Filters



ECOsine® Full Performance Line



ECOsine® Full Performance Line (THDI < 5%)

The field guide to harmonics mitigation and energy efficiency

November 2014

Luca Dalessandro, Product Marketing Manager
Norbert Häberle, Head of Group Innovation Center
Andrzej Pietkiewicz, Ph.D., Group Technology Manager

Schaffner ECOsine® harmonic filters represent an economical solution to the challenge of load-applied harmonics mitigation in three-phase power systems. With a plug-and-play approach and more compact dimensions than comparable products, they can be quickly installed and easily commissioned. They increase the reliability and service life of electric installations, help utilize electric system capacity better, and are the key to meet Power Quality standards such as IEEE Std 519-2014. ECOsine® filters help to reduce the costly waste of electric power.

This installation manual is intended to support designers, installers, and application engineers with filter selection, installation, application, and maintenance. It provides helpful tips to overcome harmonics mitigation challenges and answers frequently asked questions.

If you require additional support, please feel free to contact your local Schaffner partner.



Important user notice

Schaffner ECOsine® harmonic filters are designed for the operation on the input (grid) side of power electronic equipment with six-pulse rectifier front-ends in balanced three-phase power systems, like typically used in AC or DC motor drives and high power DC supplies. Filter suitability for a given application must be determined by the user on a case by case basis. Schaffner will not assume liability for any consequential downtimes or damages resulting from use or application of ECOsine® filters outside of their specifications. ECOsine® filters are not designed for single-phase or split-phase applications.

ECOsine® filters with protection category IP20/NEMA1 must be mounted in a clean, dry location. Contaminants such as oils, corrosive vapors and abrasive debris must be kept out of the enclosure. These filter enclosures are intended for indoor use, primarily to provide a degree of protection against contact with enclosed equipment. These enclosures offer no protection against airborne contaminants.

Important safety considerations



Note: Filter installation has to be carried out by a trained and certified electrician or technician, who is familiar with installation and safety procedures in three-phase power systems.

Warning: High voltage potentials are involved in the operation of ECOsine® filters. Always remove power before handling energized parts of the filter, and let ample time elapse (> 1 minute) for the capacitors to discharge to safe levels.

Warning: Follow the installation instructions closely. Ensure that fans and cooling slots are free from obstructions that could inhibit efficient air circulation. Do not operate the filter in ambient conditions outside of specifications.

Note: Do not operate ECOsine® filters on unsymmetrical loads, on linear loads, or with single-phase equipment.

Note: Always use an upstream disconnect or protection device as required by most national and international electric codes.

Note: Always connect the filter to protective earth (PE) first, then continue with the wiring of the trap-disconnect (if needed) and phase connectors.

Note: Follow the Schaffner instructions closely when doing maintenance work. Use exclusively spare parts recommended and approved by Schaffner.

Note: Always practice the safety instructions defined by your company when handling, installing, operating, or maintaining ECOsine® harmonic filters.

Note: In case of uncertainty and questions please contact your local Schaffner partner for assistance.



Content

1. Part number coding	5
2. Filter description	6
2.1 General electrical specifications FN 3410 and FN 3411 (50Hz filters)	6
2.2 General electrical specifications FN 3412 and FN 3413 (60Hz filters)	7
2.3 Additional electrical specifications	8
2.4 Mechanical specifications FN3410/11/12/13	9
2.5 Performance characteristics	11
2.6 Function diagram	15
2.7 External filter elements	16
2.8 Monitoring status.....	16
2.9 Audible noise	17
3. Filter purpose and function	18
4. Filter selection	20
5. Filter application	23
6. Filter installation	24
7. Filter maintenance	30
8. Special considerations	32
8.1 Over-temperature switch and load disconnect	32
8.2 Trap circuit disconnect	33
9. Application examples	34
9.1 Harmonics mitigation on an individual motor drive	34
9.2 Harmonics mitigation in applications with multiple loads in parallel	35
10. Troubleshooting	37
11. FAQ – Frequently asked questions	38
12. Custom design input form	41
Appendix I: International standards	42
I. Engineering recommendation G5/4-1	42
II. International standard EN 61000-3-12.....	44
III. IEEE Std 519	47
Appendix II: Declaration of conformity	48

1. Part number coding

FN 34xx xx -xxx -xx



Examples:

FN 3410-60-34: Filter for 50Hz, 380-500V grids, 60A drive input current, with 25mm² terminals, for diode rectifier front-end.

FN 3413-240-99: Filter for 60Hz, 380-480V grids, 240A drive input current, with copper bus bars, for SCR (thyristor) front-end.

2. Filter description

2.1 General electrical specifications FN 3410 and FN 3411 (50Hz filters)

Nominal operating voltage:	3x 380 to 500VAC
Voltage tolerance range:	3x 342 to 550VAC
Operating frequency:	50Hz ±1Hz
Network:	TN, TT, IT
Nominal motor drive input current rating: ¹⁾	10 to 320A @ 50°C
Nominal filter input current rating: ¹⁾	7A _{rms} to 240A _{rms} @ 50°C
Nominal motor drive input power rating:	4 to 200kW
Total harmonic current distortion THID: ²⁾	<5% @ rated power
Total demand distortion TDD: ²⁾	According to IEEE 519
Partially weighted harmonic distortion PWHID:	<22% @ rated power
Efficiency:	>98.5% @ nominal line voltage and power
Drive dc-link voltage behavior: ³⁾	No load: +10%
	Full load: -5%
High potential test voltage: ⁴⁾	P → E 2500VAC (1min)
SCCR: ⁵⁾	100kA
Protection category:	IP20
Pollution degree:	1, 2 (according to EN 61800-5-1, EN 50178)
Cooling:	Internal forced cooling
Overload capability:	1.6x rated current for 1 minute, once per hour 2x rated current for 10 seconds, once per hour 5x rated current for 1 second, once per hour
Capacitive current at low load:	<30% of rated input current, at 400VAC <37% of rated input current, at 500VAC
Ambient temperature range:	-25°C to +50°C fully operational +50°C to +70°C derated operation ⁶⁾ -25°C to +85°C transportation and storage
Flammability class:	UL 94V-2 or better
Insulation class of magnetic components:	H (180°C)
Design corresponding to:	UL 508, EN 61558-2-20, CE (LVD 2006/95/EC)
MTBF @ 50°C/500V (Mil-HB-217F):	>200,000 hours
MTTR:	<15 minutes (capacitors and fans)
Lifetime (calculated):	Min. 15 years
Safety monitoring functions:	Over-temperature of magnetic components
Safety monitor output signal:	NO switch

- ¹⁾ ECOsine® filters reduce RMS input and peak current by reducing harmonic currents and improving true power factor.
²⁾ System requirements: THVD <2%, line voltage unbalance <1%
 Performance specification for six-pulse diode rectifiers. SCR rectifier front-ends produce different results, depending upon the firing angle of the thyristors.
³⁾ Conditions: line impedance <3%
⁴⁾ Repetitive tests to be performed at max. 80% of above levels, for 2 seconds.
⁵⁾ External UL-rated fuses required.
⁶⁾ $I_{derated} = I_{nominal} * \sqrt{(85^{\circ}\text{C} - T_{amb}) / 35^{\circ}\text{C}}$

2.2 General electrical specifications FN 3412 and FN 3413 (60Hz filters)

Nominal operating voltage:	3x 380 to 480VAC
Voltage tolerance range:	3x 342 to 528VAC
Operating frequency:	60Hz ±1Hz
Network:	TN, TT, IT
Nominal motor drive input current rating: ¹⁾	8 to 310A @ 50°C
Nominal filter input current rating: ¹⁾	5A _{rms} to 250A _{rms} @ 50°C
Nominal motor drive input power rating:	5 to 250HP
Total harmonic current distortion THID: ²⁾	<5% @ rated power
Total demand distortion TDD: ²⁾	According to IEEE 519, table 10-3
Partially weighted harmonic distortion PWHID:	<22% @ rated power
Efficiency:	>98.5% @ nominal line voltage and power
Drive dc-link voltage behavior: ³⁾	No load: +10% Full load: -5%
High potential test voltage: ⁴⁾	P → E 2500VAC (1min)
SCCR: ⁵⁾	100kA
Protection category:	IP20
Pollution degree:	1, 2 (according to EN 61800-5-1, EN 50178)
Cooling:	Internal forced cooling
Overload capability:	1.6x rated current for 1 minute, once per hour 2x rated current for 10 seconds, once per hour 5x rated current for 1 second, once per hour
Capacitive current at low load:	<30% of rated input current, at 460VAC
Ambient temperature range:	-25°C to +50°C fully operational +50°C to +70°C derated operation ⁶⁾ -25°C to +85°C transportation and storage
Flammability class:	UL 94V-2 or better
Insulation class of magnetic components:	H (180°C)
Design corresponding to:	UL 508, EN 61558-2-20, CE (LVD 2006/95/EC)
MTBF @ 50°C/460V (Mil-HB-217F):	200,000 hours
MTTR:	<15 minutes (capacitors and fans)
Lifetime (calculated):	Min. 15 years
Safety monitoring functions:	Over-temperature of magnetic components
Safety monitor output signal:	NO switch

¹⁾ ECOSine® filters reduce RMS input and peak current by reducing harmonic currents and improving true power factor.

²⁾ System requirements: THVD <2%, line voltage unbalance <1%
 Performance specification for six-pulse diode rectifiers. SCR rectifier front-ends produce different results, depending upon the firing angle of the thyristors.

³⁾ Conditions: line impedance <3%

⁴⁾ Repetitive tests to be performed at max. 80% of above levels, for 2 seconds.

⁵⁾ External UL-rated fuses required.

⁶⁾ $I_{derated} = I_{nominal} \cdot \sqrt{(85^{\circ}\text{C} - T_{amb})/35^{\circ}\text{C}}$

2.3 Additional electrical specifications

ECOsine™ passive general electrical specifications refer to operating altitudes up to 1000m a.s.l. (3300ft). Operation between 1000m and 4000m (3300ft and 13123ft) requires a derating according to the table below:

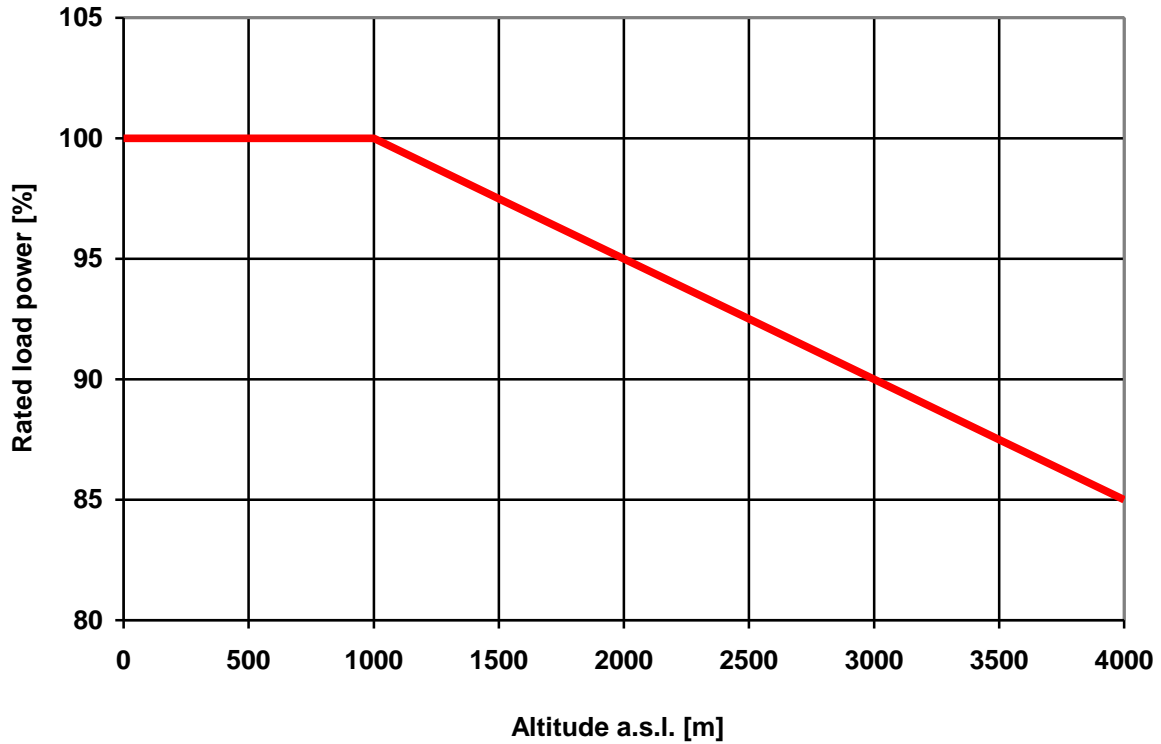

Note: do not use ECOsine® passive harmonic filters in altitudes above 4000m without consulting Schaffner first.

ECOsine® passive filters have been designed and certified acc. UL508, resp. UL508C, so there is no limitation in terms of altitude up to 4000m for clearance and creepage.

2.4 Mechanical specifications FN3410/11/12/13

Mechanical data

FN 3410/FN 3411-10 to -110

FN 3412/FN 3413-8 to -130

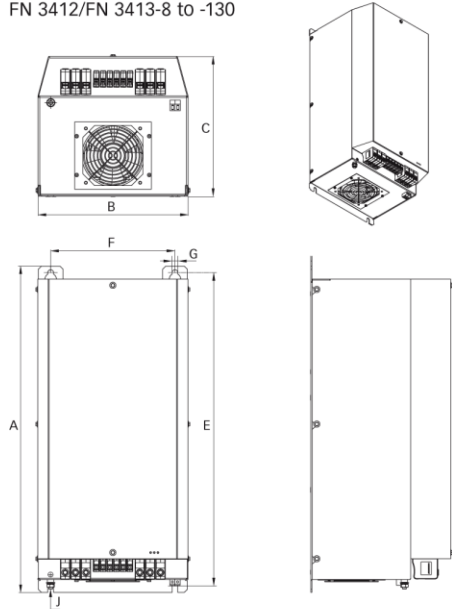

FN 3410/FN 3411-150 to -210

FN 3412/FN 3413-160 and -190

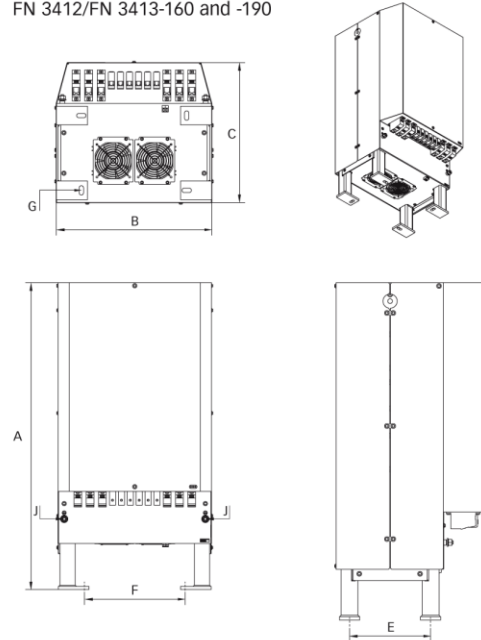

FN 3410/FN 3411-260 and -320

FN 3412/FN 3413-240 and -310

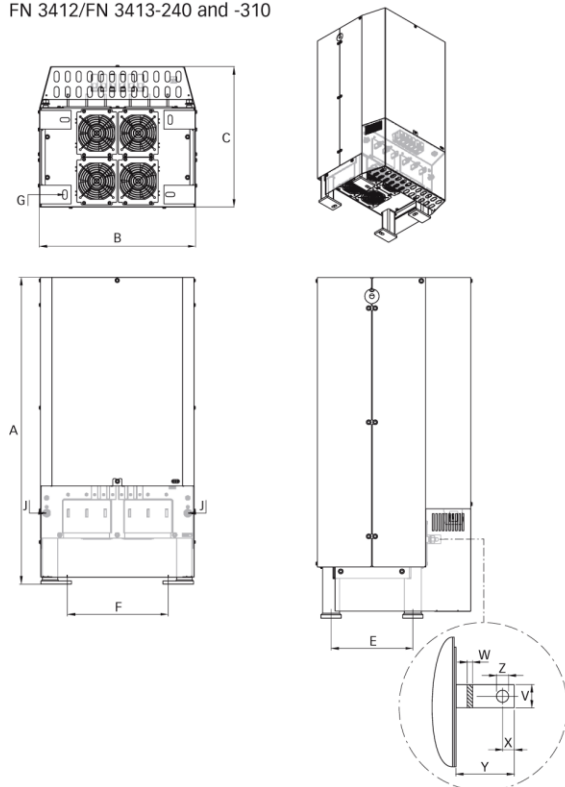

Installation. All filters from FN 341x-8 to -130 are wall mountable and have to be operated vertically. The filters FN 341x-150 and higher are designed for floor mounting. In order to allow for sufficient air flow all filters must be clear on top and bottom min. 150mm.

Optional NEMA1 cover. All filters can be optionally fitted with a NEMA1 cover. Please find order codes on previous pages.

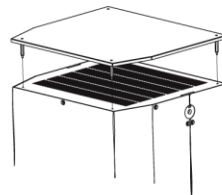





Dimensions

	10	13	16	21	24	32	38	45	60	75	90	110	150	180	210	260	320
	8	11	15		28	35	41	53	65	80	105	130	160	190		240	310
A	400	400	430	430	520	520	520	590	590	750	750	750	1000	1000	1000	1000	1000
B	170	170	210	210	250	250	250	300	300	320	320	320	500	500	500	500	500
C	190	190	210	210	280	280	280	300	300	300	300	300	450	450	450	450	450
E	380	380	410	410	495	495	495	565	565	725	725	725	240	240	240	240	240
F	130	130	170	170	200	200	200	250	250	270	270	270	338	338	338	338	338
G	7	7	9	9	11	11	11	11	11	11	11	11	14x30	14x30	14x30	14x30	14x30
J	M6	M6	M6	M6	M8	M8	M8	M8	M8	M10	M10	M10	M10	M10	M10	M10	M10
V																	25
W																	6
X																	12.5
Y																	40
Z																	11

All dimensions in mm; 1 inch = 25.4mm
 Tolerances according: ISO 2768-m / EN 22768-m

Filter connector cross sections

	-33	-34	-35	-40	-44
					
Solid wire	16mm ²	35mm ²	50mm ²	95mm ²	10mm ²
Flex wire	10mm ²	25mm ²	50mm ²	95mm ²	6mm ²
AWG type wire	AWG 6	AWG 2	AWG 1/0	AWG 4/0	AWG 8
Recommended torque	1.5 – 1.8Nm	4.0 – 4.5Nm	7 – 8Nm	17 – 20Nm	1.0 – 1.2Nm

Please visit www.schaffner.com to find more details on filter connectors.

2.5 Performance characteristics

THID vs. load (diode rectifier front-ends)

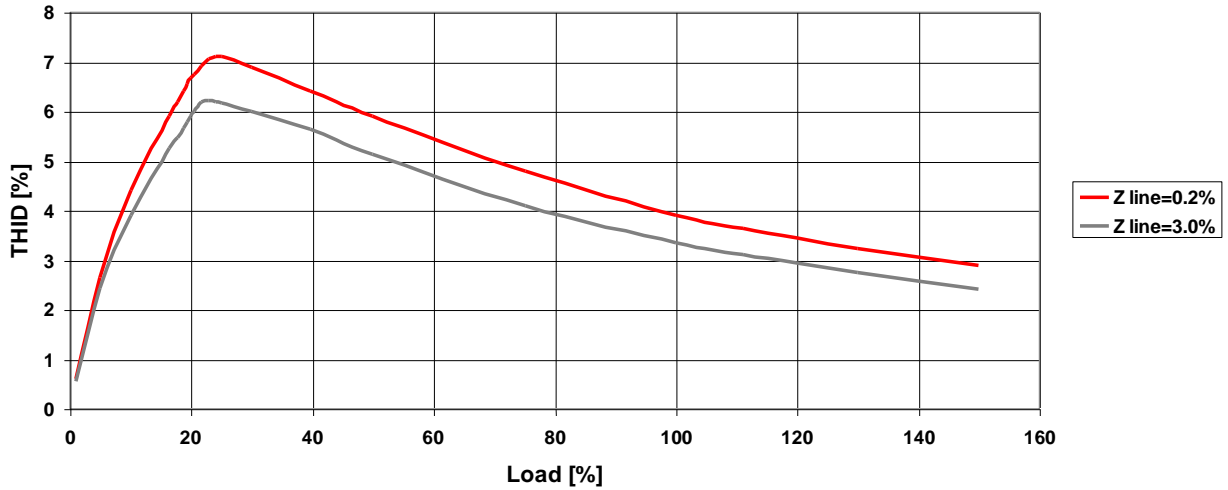

Note: shown above is the typical behaviour of FN3410/12 up to 200kW.

THID vs. load (SCR rectifier front-ends)

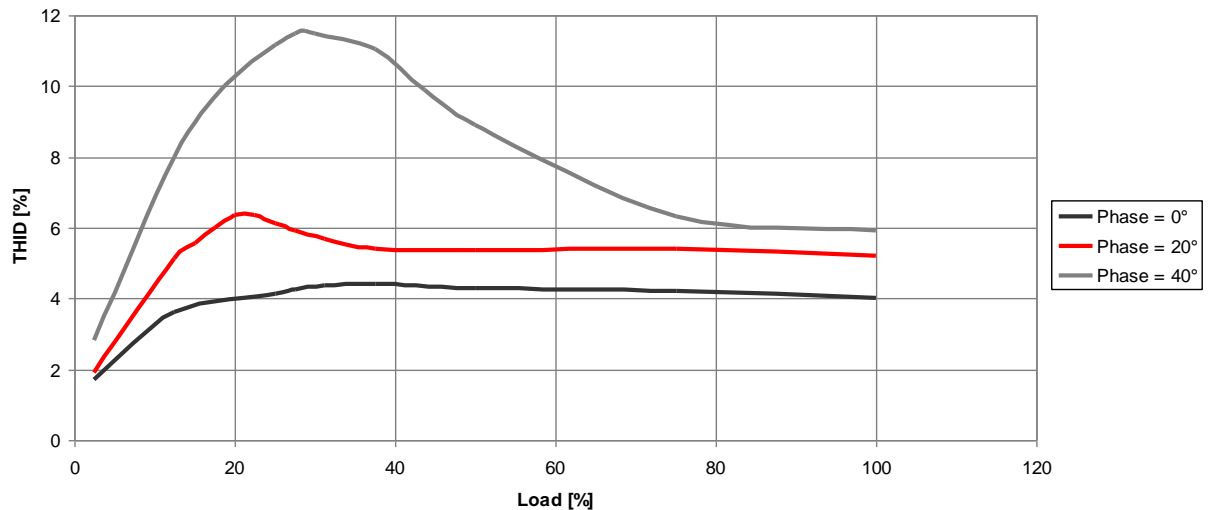

In SCR rectifier applications, filter performance greatly depends upon the firing angle of the thyristors.

TDD vs. load (diode rectifier front-ends)

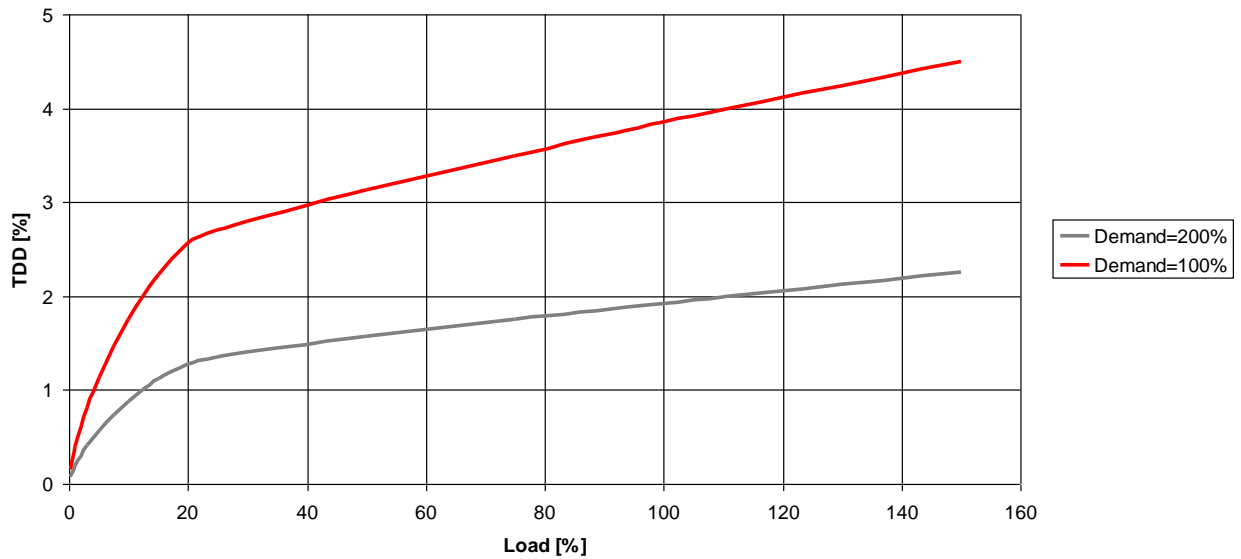

Demand=100%: means that maximum demand at PCC is equal to 100% of maximum fundamental component of nonlinear load;

Demand=200%: means that maximum demand at PCC is equal to 200% (100% nonlinear load + 100% additional linear load)

TDD vs. load (SCR rectifier front-ends)

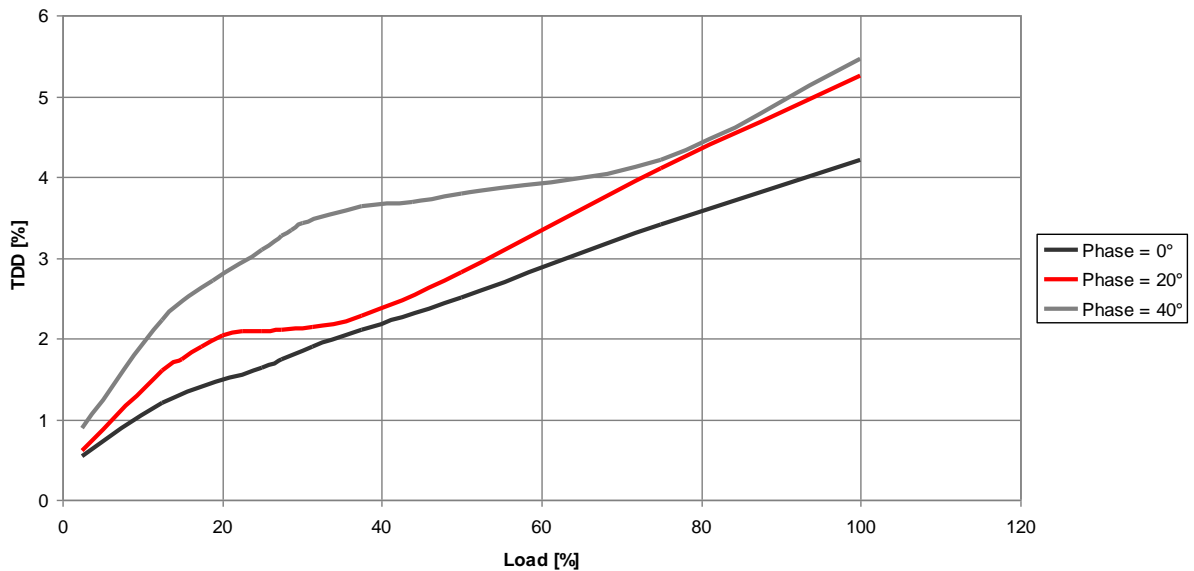

In SCR rectifier applications, filter performance greatly depends upon the firing angle of the thyristors.

Power factor vs. load (diode rectifier front-ends)

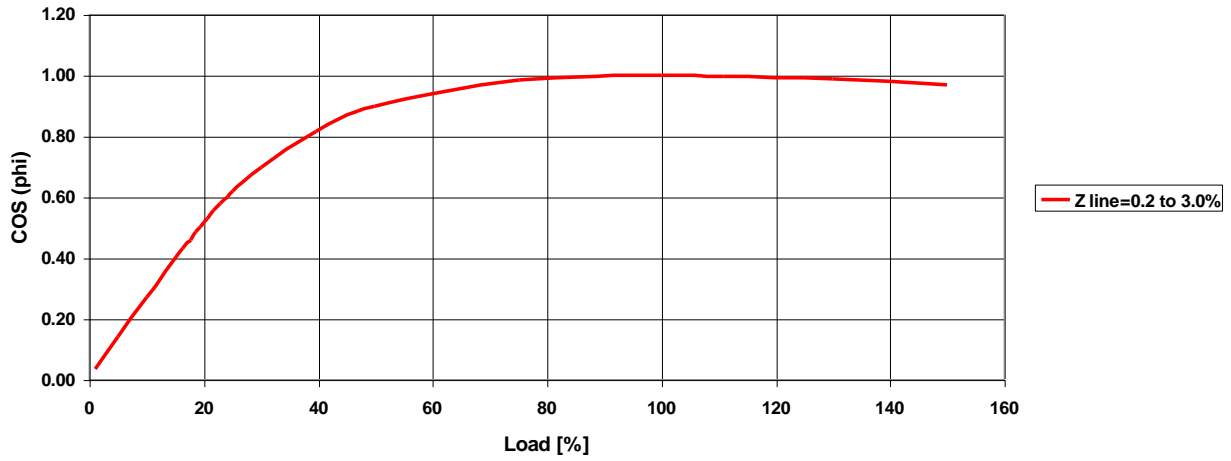

Power factor vs. load (SCR rectifier front-ends)

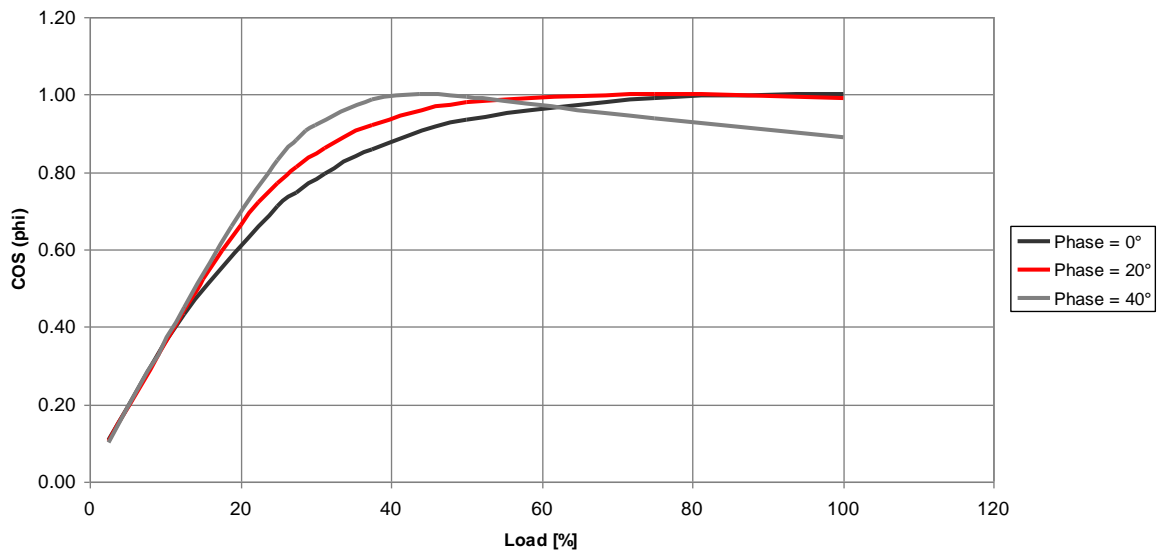

In SCR rectifier applications, filter characteristics greatly depend upon the firing angle of the thyristors.

Drive dc-link voltage vs. load (diode rectifier front-ends)

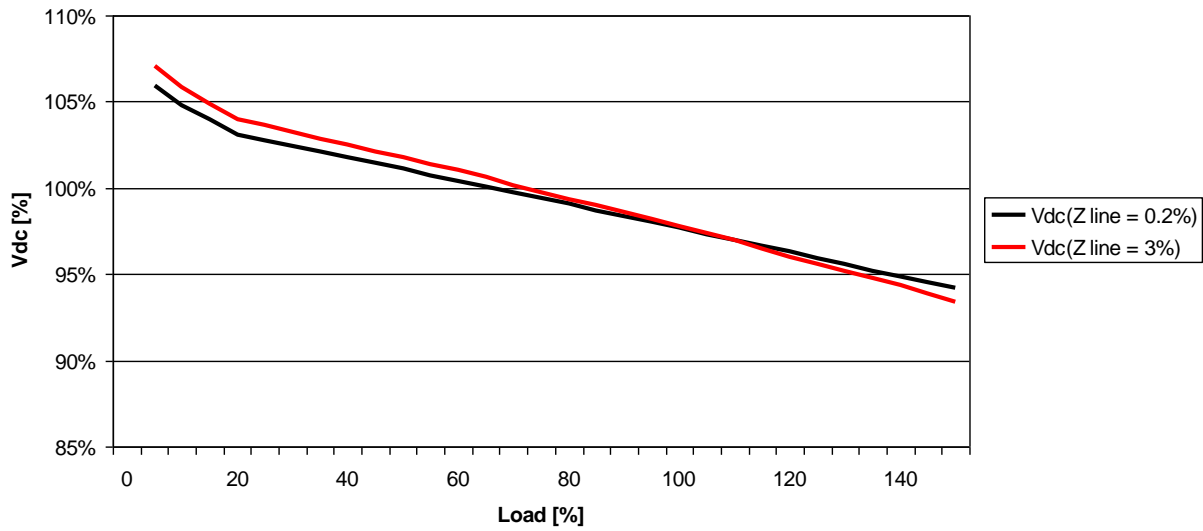

Drive dc-link voltage vs. load (SCR rectifier front-ends)

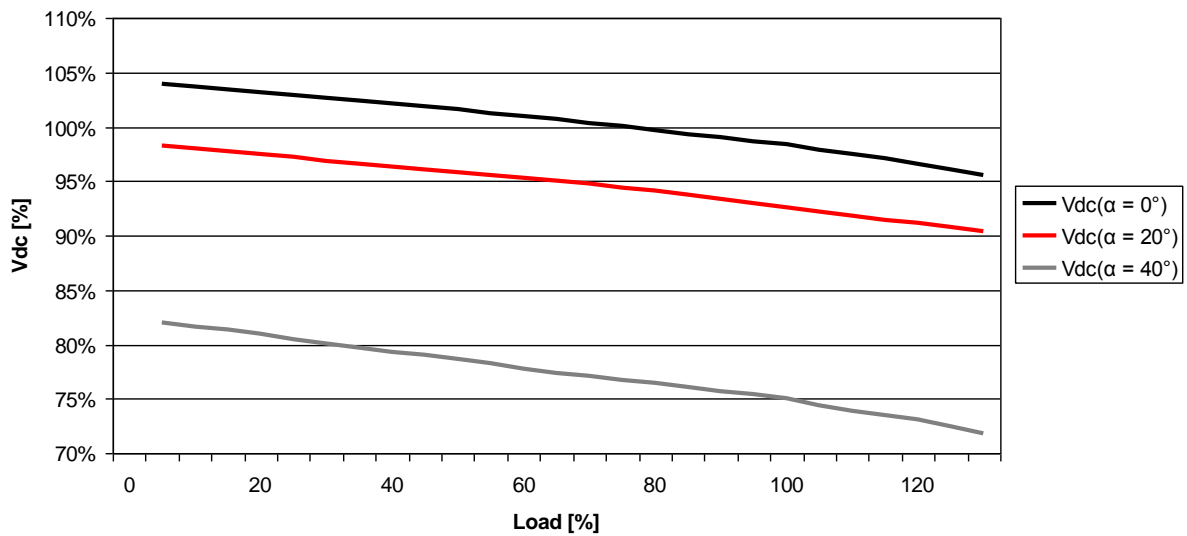

In SCR rectifier applications, filter characteristics greatly depend upon the firing angle of the thyristors.

2.6 Function diagram

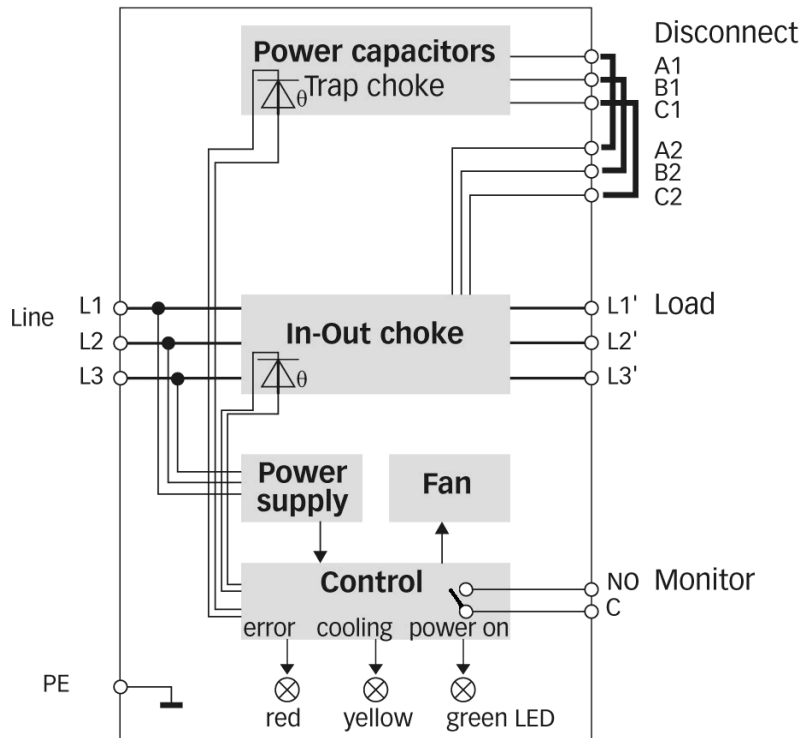

Filter terminals	Line	3 touch safe terminal blocks (busbar terminals >240A)
	Load	3 touch safe terminal blocks (busbar terminals >240A)
	Monitor	NO switch, 250VAC/3A, touch safe terminal 4mm ²
		Open position indicates error
	PE	Protective earth. Threaded stud with washer and nut
	Trap disconnect	Touch safe terminals. Upon delivery, wire bridges are installed for immediate operation of the filter. They allow for the connection of an external contactor for load dependent disconnection of the trap circuit, if needed.

Function blocks	Chokes	Power magnetic components incl. temperature sensors
	Capacitors	Power capacitors incl. discharge resistors
	Fan	Field replaceable fan for choke cooling
	Power supply	Internally generated 24VDC for fan supply
	Control	Temperature monitoring Monitor switch triggering LED readout

2.7 External filter elements

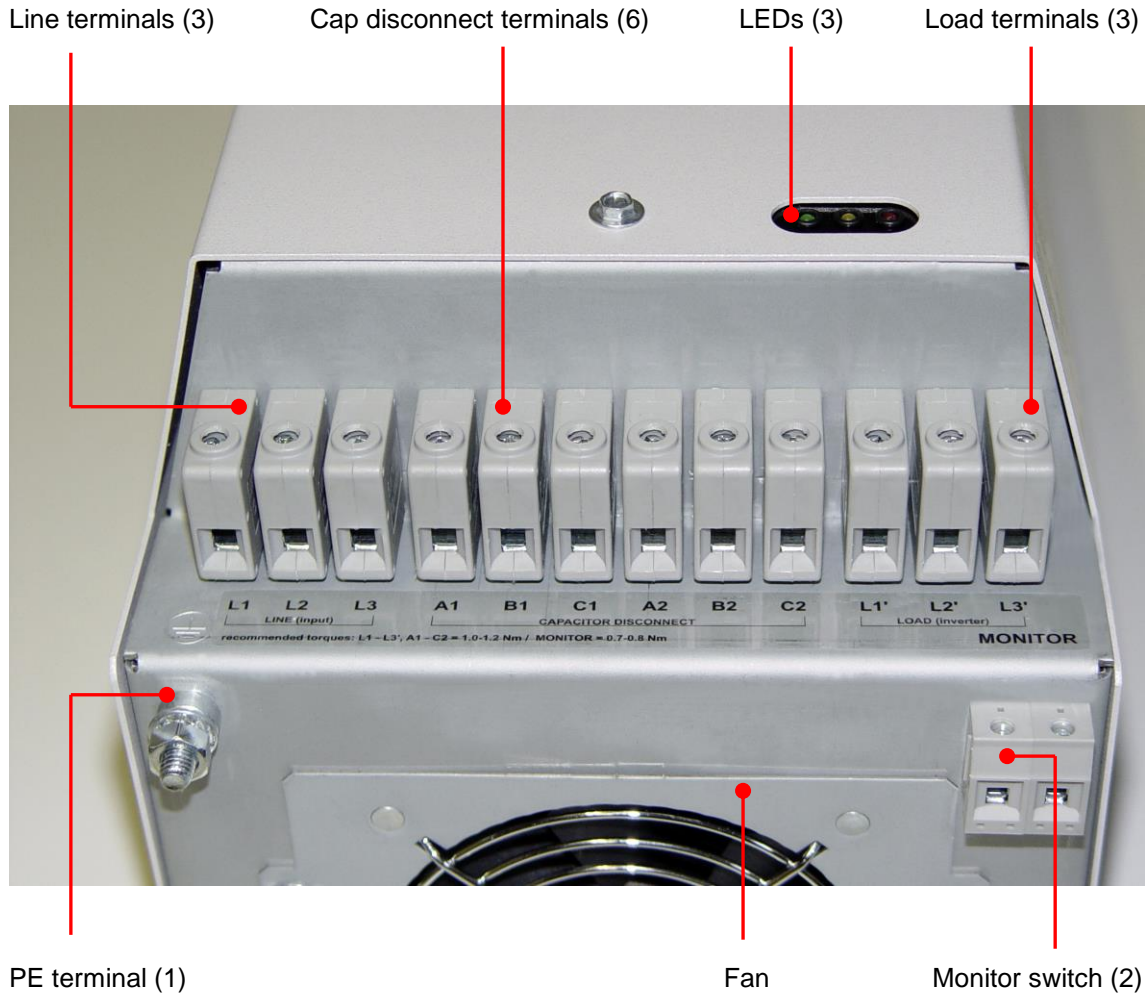

2.8 Monitoring status

LEDs	Monitor switch	Filter state
		Power off
		Power on, internal temperature does not require fan
		Power on, active fan cooling
		Power on, over-temperature or fan error *
		Power on, sensor short or monitor error

* Fan or sensor disconnection is recognized

2.9 Audible noise

Tests have been performed with nominal load and with/without fan running. Ambient noise level: 47dB[A]

Filter	Fans OFF	Fans ON
FN 3410-13-44 (P=5.5kW)	50dB[A] @ 1m	57dB[A] @ 1m
FN 3410-32-33 (P=15kW)	57dB[A] @ 1m	60dB[A] @ 1m
FN 3410-75-35 (P=37kW)	66dB[A] @ 1m	70dB[A] @ 1m
FN 3410-320-99 (P=160kW)	tbd	tbd

Equipment used: Peak Tech Sound Level Meter 5055

3. Filter purpose and function

ECOsine® harmonic filters are based on passive LCR filtering technology. They are intended for the operation on the input side of balanced three-phase six-pulse rectifiers, like commonly used in inverters for motor drives.

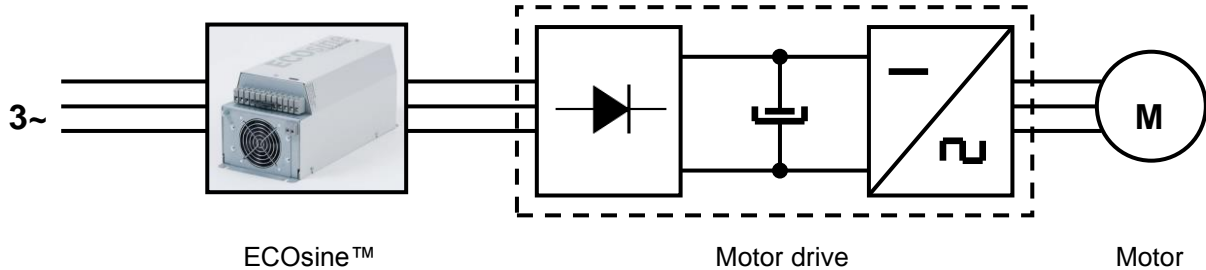

Six-pulse rectifiers inherently draw current in a non-sinusoidal fashion from the grid, creating a current wave form rich in harmonics. Harmonic currents flow through system impedances and create harmonic voltages. Both harmonic currents and voltages give rise to serious issues, such as electric system overload, reliability problems, and violations against international standards and utility codes.

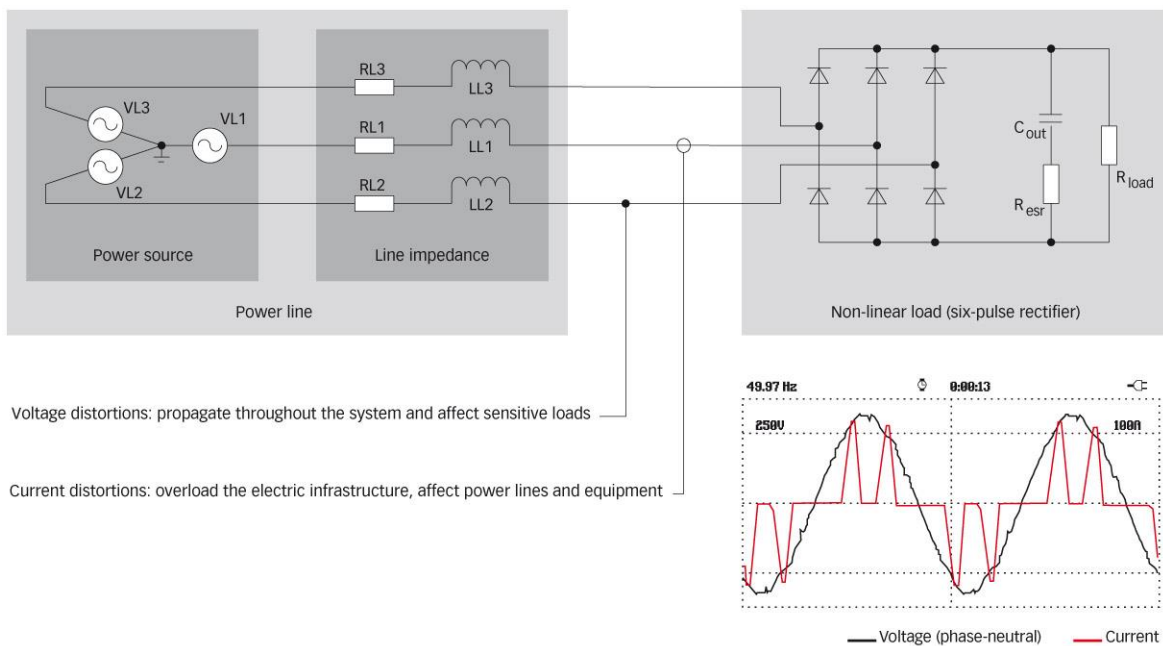

ECOsine® filters efficiently reduce the harmonic currents to negligible levels and ensure, that a sine-wave current is drawn from the grid. In the process, they also reduce peak currents and RMS input current, allowing for lower wire cross sections in conductors, smaller fuses, breakers, and transformers. In existing installations, more drives can be used on the same distribution transformer.

The example on the next page visualizes typical performance test results with and without a Schaffner ECOsine® harmonic filter FN 3410-13-44 for the same real load power of 6kW.

Without ECOSine® filter

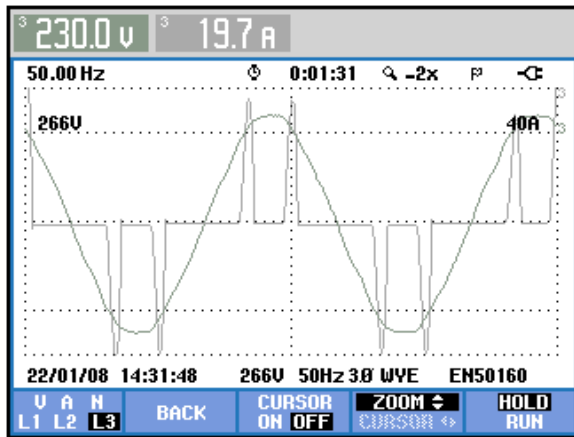

Voltage and current waveforms

With ECOSine® filter

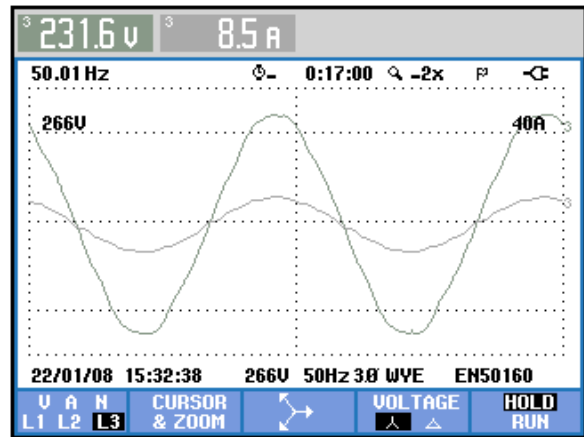

Voltage and current waveforms

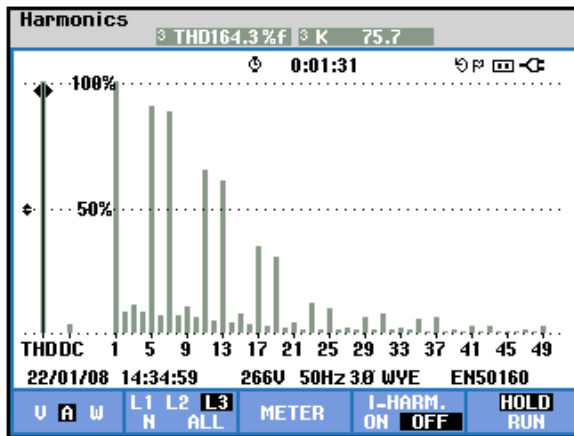

Current harmonics THD = 164.3% (scale 0-100%)

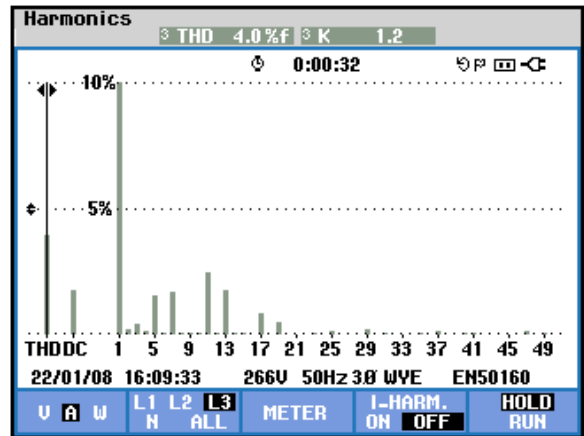

Current Harmonics THD = 4.0% (scale 0-10%)

Power & Energy

	L1	L2	L3	Total
kW	1.68	1.75	2.43	5.87
kVA	3.59	3.76	4.67	12.10
kVAR	3.17	3.32	3.99	4.15
PF	0.47	0.47	0.52	0.49
Cosφ	0.98	0.96	1.00	
Arms	15.7	16.4	20.3	
<hr/>				
	L1	L2	L3	
V _{rms}	228.7	229.4	230.0	

Power, PF, Cosφ, Current

Power & Energy

	L1	L2	L3	Total
kW	1.97	1.98	1.98	5.92
kVA	1.97	1.98	1.99	5.93
kVAR	0.11	0.10	0.11	0.32
PF	1.00	1.00	1.00	1.00
Cosφ	1.00	1.00	1.00	
Arms	8.6	8.6	8.6	
<hr/>				
	L1	L2	L3	
V _{rms}	230.1	230.3	231.4	

Power, PF, Cosφ, Current

4. Filter selection

ECOsine® harmonic filters need to be carefully selected in order to enjoy maximum benefits.

Step 1: rectifier topology of the non-linear load

Determine, whether the non-linear load in question (e.g. motor drive) has a diode or thyristor rectifier front-end, and select the proper filter family according to the following table:

For six-pulse diode rectifiers (6 diodes)	FN 3410 / FN 3412
For six-pulse mixed rectifiers (3 diodes, 3 thyristors*)	FN 3410 / FN 3412
For six-pulse SCR rectifiers (6 thyristors)	FN 3411 / FN 3413

* for soft starting purposes in AC drives only.

Step 2: grid frequency

Determine, whether the system in question will be operated in a 50Hz or 60Hz electricity grid, and select the corresponding filter family according to the following table:

50Hz grid	Europe, Middle East, parts of Asia, parts of South America	FN 3410 / FN 3411
60Hz grid	North and Central America, parts of Asia, parts of South America	FN 3412 / FN 3413

Note: a 50Hz filter will not provide satisfying harmonics mitigation in a 60Hz grid, and vice versa.

Step 3: grid configuration

Verify, that the grid configuration is suitable for standard ECOsine™ harmonic filters according to the following table:

50Hz grid	Nominal voltage 380-500VAC ±10%	TN, TT, IT configuration
50Hz grid	Nominal voltage 690VAC ±10%	TN, TT, IT configuration
60Hz grid	Nominal voltage 380-480VAC ±10%	TN, TT, IT configuration

Note: filters for 600V/60Hz, as well as single-phase filters, are available upon request.

Step 4: real rectifier/drive input power

The individual filter must be selected by the actual rectifier/drive input real power (kW, HP). It is important to select the filter as close as possible to the effective input power of the rectifier/drive.

Note that FN 3410 and FN 3411 (50Hz) filters show double ratings in the selection table. Depending upon the grid voltage, the same filter is rated for two different rectifier/drive input real power values. For 380/400/415V lines, the filters have a lower power rating than for 500V systems.

Note that if the rectifier/drive is being operated very close to its rated power, then the filter can be selected by the motor drive's nominal power rating. However, if the drive will be operated e.g. at only 66% of its rated power, then a smaller filter should be selected in order to get maximum harmonics mitigation performance and the optimum in terms of cost, size, and weight.

Please refer to the following examples:

Example 1:

Power line rating: 400V, 50Hz

Drive rating: 380-500V, 50-60Hz, 15kW, 22.5A, diode rectifier

Planned rectifier/drive input real power: 15kW (100% of drive rating)

➔ **Recommended filter according to the filter selection table FN 3410: Type FN 3410-32-33**

Example 2:

Power line rating: 500V, 50Hz

Drive rating: 380-500V, 50-60Hz, 15kW, 22.5A, diode rectifier

Planned rectifier/drive input real power: 15kW (100% of drive rating)

➔ **Recommended filter according to the filter selection table FN 3410: Type FN 3410-24-33**

Example 3:

Power line rating: 400V, 50Hz

Drive rating: 380-500V, 50-60Hz, 15kW, 22.5A, diode rectifier

Planned rectifier/drive input real power: 10kW (66% of drive rating)

➔ **Recommended filter according to the filter selection table FN 3410: Type FN 3410-24-33**

Example 4:

Power line rating: 500V, 50Hz

Drive rating: 380-500V, 50-60Hz, 15kW, 22.5A, diode rectifier

Planned rectifier/drive input real power: 10kW (66% of drive rating)



➔ **Recommended filter according to the filter selection table FN 3410: Type FN 3410-16-44**

OVERRATING THE FILTER DOES NEVER MAKE SENSE, BECAUSE OF THE INHERENT LOWER HARMONICS MITIGATION PERFORMANCE AT LIGHT LOAD, AS WELL AS HIGHER PRICE, SIZE, AND WEIGHT.

Please refer to the selection tables on the next page.

Filter selection table FN 3410 and FN 3411 (50Hz)



Filter selection table

Filter*	Rated load power @ 400VAC/50Hz	Rated load power @ 500VAC/50Hz	Power loss** @ 400V/500V	Input/Output connections	Capacitor disconnections	Weight	NEMA1 covers***
	[kW]	[kW]	[W]	 		[kg]	Order code
FN 341x-10-44	4	5.5	60/83	-44	-44	13	803565
FN 341x-13-44	5.5	7.5	83/113	-44	-44	14	803565
FN 341x-16-44	7.5	11	113/165	-44	-44	21	803566
FN 341x-24-33	11	15	165/225	-33	-44	27	803567
FN 341x-32-33	15	18.5	225/278	-33	-44	31	803567
FN 341x-38-33	18.5	22	259/308	-33	-44	35	803567
FN 341x-45-34	22	30	286/390	-34	-33	45	803568
FN 341x-60-34	30	37	360/444	-34	-33	54	803568
FN 341x-75-35	37	45	407/495	-35	-34	65	803569
FN 341x-90-35	45	55	450/550	-35	-34	77	803569
FN 341x-110-35	55	75	495/675	-35	-34	86	803569
FN 341x-150-40	75	90	600/720	-40	-35	118	803570
FN 341x-180-40	90	110	630/770	-40	-35	136	803570
FN 341x-210-40	110	132	770/924	-40	-35	154	803570
FN 341x-260-99	132	160	792/960	-99	-35	201	803570
FN 341x-320-99	160	200	960/1200	-99	-35	201	803570

- * To compile a complete part number, please replace the x with a 0 for diode or 1 for SCR rectifiers.
 Filter to be selected by system voltage and load (motor drive) power. Note: the harmonic filter will reduce the RMS input current. Example: the rated RMS input current of an unfiltered 400V/15kW/32A drive will be reduced to approximately 23A. Therefore, filter selection by current rating, as it is common for EMC/EMI filters, is not suitable.
- ** Calculated power loss at rated load power.
- *** Please contact your local Schaffner partner to order the optional NEMA1 covers with the order code in the table above.

Filter selection table FN 3412 and FN 3413 (60Hz)

Filter selection table

Filter*	Rated load power @ 460VAC/60Hz	Power loss** @ 460V	Input/Output connections	Capacitor disconnections	Weight	NEMA1 covers***
	[HP]	[W]	 		[kg]	Order code
FN 341x-8-44	5	56	-44	-44	12	803565
FN 341x-11-44	7.5	84	-44	-44	13	803565
FN 341x-15-44	10	112	-44	-44	17	803566
FN 341x-21-44	15	168	-44	-44	21	803566
FN 341x-28-33	20	209	-33	-44	28	803567
FN 341x-35-33	25	261	-33	-44	32	803567
FN 341x-41-33	30	291	-33	-33	35	803567
FN 341x-53-34	40	328	-34	-33	48	803568
FN 341x-65-34	50	373	-34	-34	52	803568
FN 341x-80-35	60	403	-35	-34	69	803569
FN 341x-105-35	75	447	-35	-34	77	803569
FN 341x-130-35	100	522	-35	-35	87	803569
FN 341x-160-40	125	559	-40	-35	124	803570
FN 341x-190-40	150	671	-40	-35	132	803570
FN 341x-240-99	200	746	-99	-35	185	803570
FN 341x-310-99	250	932	-99	-35	202	803570

- * To compile a complete part number, please replace the x with a 2 for diode or 3 for SCR rectifiers.
 Filter to be selected by system voltage and load (motor drive) power. Note: the harmonic filter will reduce the RMS input current. Example: the rated RMS input current of an unfiltered 460V/20HP/28A drive will be reduced to approximately 20A. Therefore, filter selection by current rating, as it is common for EMC/EMI filters, is not suitable.
- ** Calculated power loss at rated load power.
- *** Please contact your local Schaffner partner to order the optional NEMA1 covers with the order code in the table above.

5. Filter application

ECOSine® filters are designed as “load-applied” filters. In contrary to “bus-applied” filters, which are being installed e.g. at the main power bus of a building, they are specifically designed to be used with either an individual non-linear load, or with a group of non-linear loads.

One advantage of load-applied filtering is the fact that the upstream power (relative to the harmonic filter) is clean. This can be of vital importance when the same power bus supplies both motor drives and sensitive loads. One example could be the elevator drives or HVAC drives in a hospital, where power must be very clean for all the sensitive medical devices. In such a case, it would not be sufficient to use a central harmonic filter at the PCC for IEEE Std 519-2014 compliance purposes.

ECOSine® filters are also suitable for paralleling lower power non-linear loads on a higher power harmonic filter to improve overall system economy. In this case the total expected load power of all connected drives must match the filter.

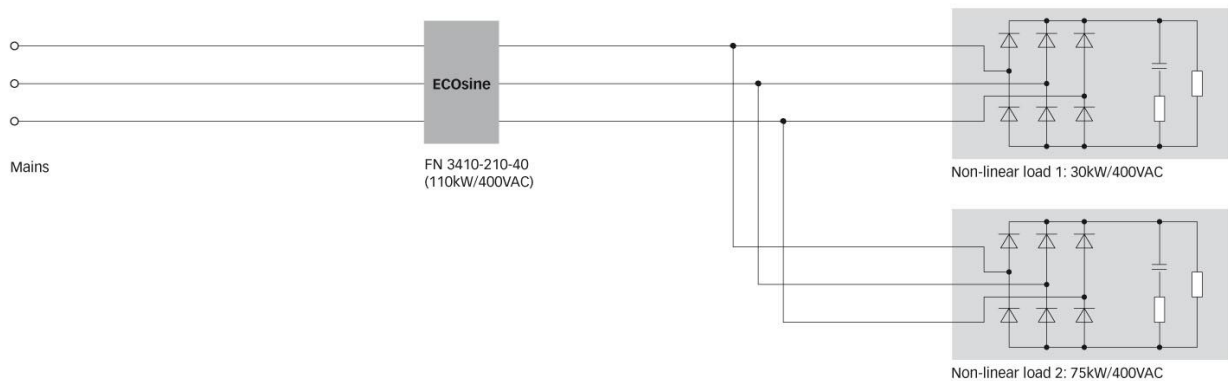

If the expected input power exceeds the rating of the largest available filter, and a custom solution is not desired, then two or more filters can be wired in parallel. In this mode of operation, it is recommended to use filters with equal power ratings to ensure proper current sharing.

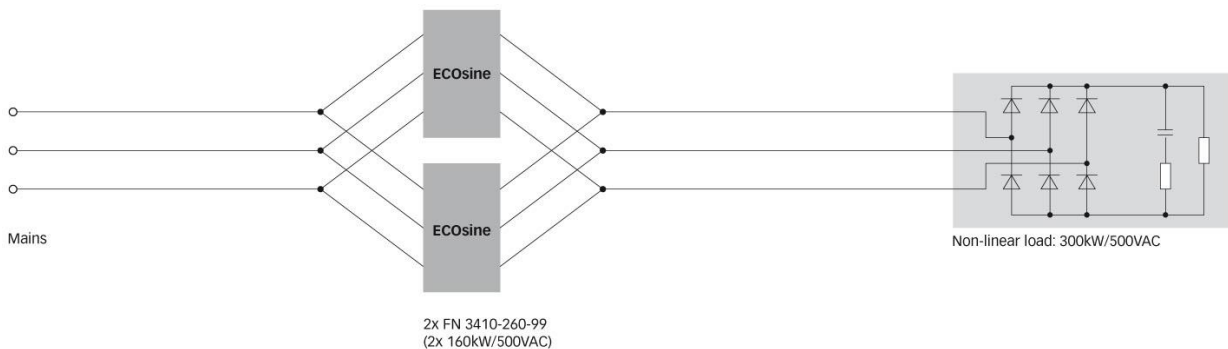

AC line reactors and/or dc-link chokes are not required when ECOSine® filters are installed. For a new system, this situation helps to offset a good portion of the harmonic filter cost. If a harmonic filter is added to a drive with an existing AC line reactor, it is recommended to remove the reactor if possible.

6. Filter installation

Please follow the few simple steps below to ensure a safe and satisfying filter function for many years.

Step 1: Visual inspection

All Schaffner ECOSine® filters have undergone rigorous testing before they left our ISO 9001:2008 certified factory. They are packaged with great care in a sturdy container for international shipment.

However, carefully inspect the shipping container for damage that may have occurred in transit. Then unpack the filter and carefully inspect for any signs of damage. Save the shipping container for future transportation of the filter.

In the case of damage, please file a claim with the freight carrier involved immediately and contact your local Schaffner partner for support. Under no circumstances install and energize a filter with visible transportation damage.

If the filter is not going to be put in service upon receipt, store within the original container in a clean, dry location, free of dust and chemicals.

Step 2: Mounting

ECOSine® load-applied filters are best installed as close as possible to the non-linear load in question. Ideally they are mounted next to the rectifier or motor drive inside the electrical cabinet or control room.

ECOSine® comes in two different installation designs:

FN 3410, FN 3411	Filters from 4 to 55kW	For vertical wall mounting
FN 3410, FN 3411	Filters from 75 to 160kW	For upright floor mounting
FN 3412, FN 3413	Filters from 5 to 100HP	For vertical wall mounting
FN 3412, FN 3413	Filters from 125 to 250HP	For upright floor mounting

Note: Filters for vertical wall mounting must not be installed horizontally. Horizontal installation will negatively affect air flow and the life time of the filter.

Important:

In order to ensure sufficient air flow, keep a clearance of min.150mm above and below the filter to walls or other components.

A 100mm clearance on either side is recommended for the possibility to comfortably open the cover in case of field maintenance.

Additional work to access the device, caused by not respected clear distances, will be accounted separately.

It must be ensured that the environmental temperature is kept below 50°C with appropriate thermal management (e.g. cabinet cooling). Filter operation in warmer environments require temperature derating.

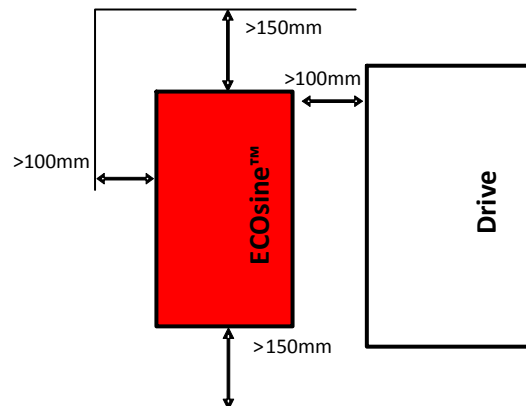

2.1 Screw hole positions for wall mounted filters:

FN 3410/FN 3411	FN 3412/FN 3413	H	W	D
-10, -13	-8, -11	380	130	M6
-16	-15, -21	410	170	M8
-24, -32, -38	-28, -35, -41	495	200	M10
-45, -60	-53, -65	565	250	M10
-75, -90, -110	-80, -105, -130	725	M10	

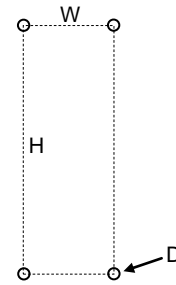

All dimensions in mm; 1 inch = 25.4mm

Note: the numbers (e.g. -10) are in reference to the middle part of the ECOsine part number coding (e.g. FN 3410-10-44)

2.2 Screw selection: Schaffner recommends zinc coated hex ribbed flange steel bolts. Respect filter weight for appropriate choice of screws! Head diameters must not exceed these dimensions:

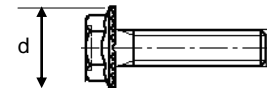

M6: $d \leq 14.2\text{mm}$, M8: $d \leq 18.2\text{mm}$, M10: $d \leq 21.2\text{mm}$
 M12: $d \leq 25\text{mm}$

2.3 Filter placement:

1. Set screws loose into wall, leave 5mm distance from head to wall.
2. Lift filter with appropriate crane, using lifting eye bolt (attached in package) – smallest types (up to 20kg) may be lifted manually by two persons (no lifting eye bolt applicable).
3. Place filter first onto lower screws...
4. ...then position it through backplane head openings on upper screws.
5. Fix screws with appropriate torque (depending upon the material of the back plane and local standards).

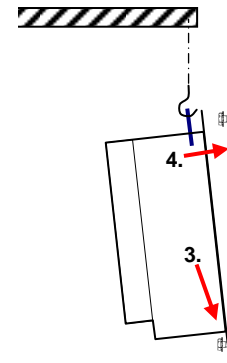

2.4 Filter types FN 3410/FN 3411-150, FN 3412/FN 3413-160 and above are floor mounting (upright) designs . It is recommended to bolt them permanently to the floor with four screws. Screw hole positions:

FN 3410/FN 3411	FN 3412/FN 3413	A	B	D
-150, -180, -210	-160, -190	336	240	M12
-260, -320	-240, -310			

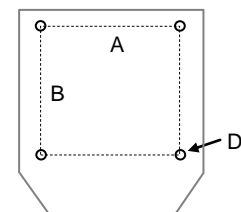

All dimensions in mm; 1 inch = 25.4mm

2.5 Important:

Handling of floor mounting designs: Use lifting eye bolts, which can be fixed on both sides of the filter. Caution has to be taken because of high product weight.

Never attempt to handle the filter with a forklift (once it is unpacked) by placing the fork between filter legs. This procedure can tip over the filter and/or damage the base of the filter.

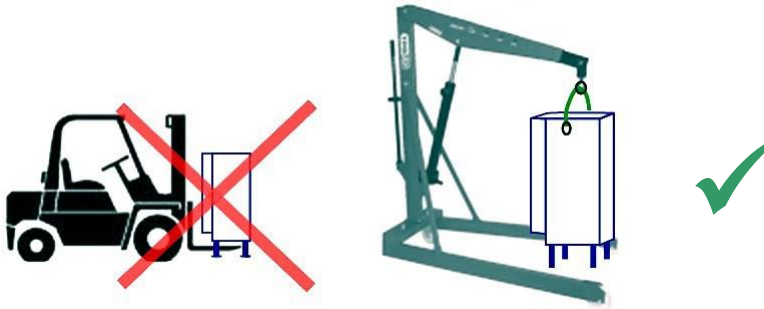

Step 3: Wiring

3.1 Verify safe disconnection of all line side power.

Consult your local safety instructions.



3.2 IP20 cover for filters with bus-bar terminals.

The filters with bus-bar terminals (FN 3410/FN 3411-260-99, FN 3412/FN 3413-240-99 and larger) are equipped with an IP20 rated cover for safety reasons.

Remove bolts on both sides of the cover, untighten the bolt on the front side to remove the cover.

Wires can be comfortably routed from the back side of the filter (in between the filter legs) to the terminals (refer to the picture to the right).

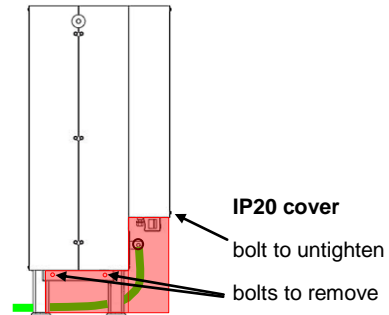

3.3 Carefully connect protective earth (PE) wire to adequate earth potential close to ECOsine® filter.

Use a wire diameter of equal or bigger size as foreseen for line/load side power cables – according to your local codes and safety instructions.

3.4 Connect PE wire on lower left side of ECOsine™

with appropriate cable lug to threaded stud.

- max. torque M6: 4Nm
- max. torque M8: 10Nm
- max. torque M10: 18Nm

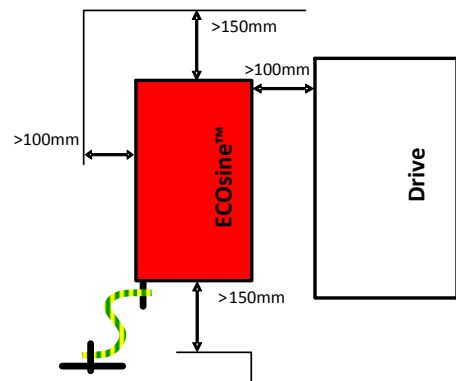

3.5 Connect ECOsine® load side terminals L1', L2', L3' to respective motor drive or rectifier inputs.

Last two digits of ECOsine® part number, i.e. FN 3412-65-**34**, indicate terminal type. See table to the right for recommended wire size and torque.

Use stranded copper wire with a temperature rating of 75°C or higher.

Terminal	Wire AWG	Wire mm ²	Torque Nm
-44	8	6	1.0 - 1.2
-33	6	10	1.5 - 1.8
-53	4	16	2.0 - 2.3
-34	2	25	4.0 - 4.5
-35	1/0	50	7.0 - 8.0
-40	4/0	95	17 - 20
-99	6/0	150	25 - 30

3.6 Use wired trap circuit (default) or install external capacitive current control.

Terminals A1-A2, B1-B2 and C1-C2 are delivered with installed jumpers. When interconnected via an external capacitor contactor (not supplied by Schaffner) they allow for load dependent disconnection of the trap circuit, if needed. Thus capacitive current can be minimized for low load operation. Estimation of required contactor size: see box to the right.

Contactor performance estimate:

Example: FN 3412-**65**-34

Divide rated load current by 2,
 multiply with nominal 3-phase
 voltage, i.e. 460VAC

$(65/2 * 460 = \sim 15\text{kVAR})$

**USE ONLY CAPACITOR CONTACTORS FOR
 MINIMIZATION OF INRUSH CURRENT. OTHERWISE
 CAPACITOR LIFETIME MAY BE REDUCED.**

3.7 Connect monitor switch

The monitor switch is a relay contact, which is open in OFF and ALARM state. Its load rating is 250VAC/30VDC/3A. It may either be used to remotely disconnect the drive's load via respective input of drive control (check drive manual) or as alarm sensor for system control unit.

**AN ENGAGED MONITOR SWITCH
 MUST LEAD TO IMMEDIATE LOAD
 SHUTDOWN AND INVESTIGATION
 OF THE PROBLEM.**

3.8 Connect ECOSine® line side terminals L1, L2, L3 to power input protection (current limiting fuses – see below).

3.9 Fuses

ECOSine® filters need external over-current protection for compliance with UL/cUL standard. Fuses and associated fuseholders must be UL listed and rated for 100kA SCCR supplies. The subsequent list shows requested fuse current ratings for UL class J and, where UL compliance is not mandatory, for IEC class gG. The fuse rating is independent of the supply voltage.

ECOSine™ type	Fuse class J <i>rated A</i>	ECOSine™ type	Fuse class J <i>rated A</i>	Fuse class gG <i>rated A</i>
FN 3412/13		All FN 3410/11		
FN 341x-8-44	8	FN 341x-10-44	10	10
FN 341x-11-44	10	FN 341x-13-44	15	10
FN 341x-15-44	15	FN 341x-16-44	20	16
FN 341x-21-44	25	FN 341x-24-33	25	20
FN 341x-28-33	30	FN 341x-32-33	35	35
FN 341x-35-33	35	FN 341x-38-33	40	35
FN 341x-41-33	45	FN 341x-45-34	50	50
FN 341x-53-34	60	FN 341x-60-34	75	63
FN 341x-65-34	70	FN 341x-75-35	80	80
FN 341x-80-35	90	FN 341x-90-35	100	100
FN 341x-105-35	110	FN 341x-110-35	150	125
FN 341x-130-35	150	FN 341x-150-40	175	160
FN 341x-160-40	175	FN 341x-180-40	200	200
FN 341x-190-40	225	FN 341x-210-40	250	224
FN 341x-240-99	300	FN 341x-260-99	300	250
FN 341x-310-99	400	FN 341x-320-99	350	300

A system with multiple ECOSine® filters paralleled for a high power load need each a separate 3-phase line side fuse block, corresponding to the respective filter and according to above table. The drive's application manual may prescribe line-side fuse protection as well, which in this case either corresponds to the sum of the filter fuse ratings or, if lower, would request separate drive fuses at its input.

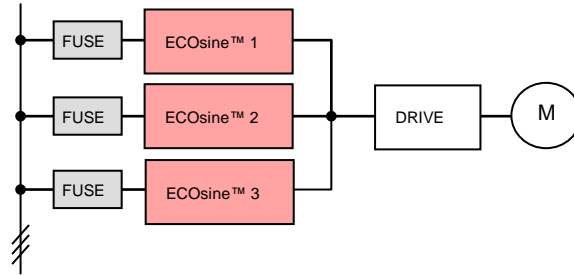

An application, having one ECOSine® filtering harmonics of several drives, requires in any case line side fuse protection of the drives as well as the correct filter protection according to above table.

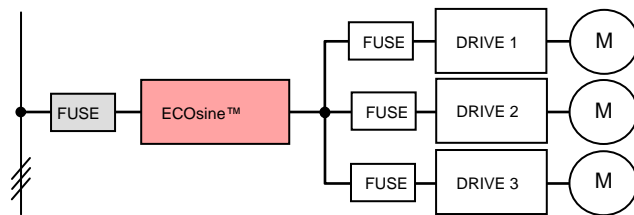

3.10 IP20 safety cover for filters with bus-bar terminals.

Once all filter terminals are properly wired, replace the safety cover by tightening the previously removed/untightened bolts.

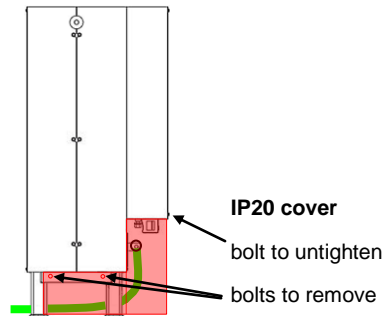

7. Filter maintenance

Schaffner ECOsine® filters are reliable low maintenance products. Many products like power supplies, inverters, or motor drives utilize fans for forced cooling to minimize the size and weight. ECOsine™ filters are designed with a similar temperature management concept and therefore, fans may have to be maintained and replaced in certain intervals to sustain the function and value of the product. Fans are 100% field replaceable without the need to uninstall and disconnect the filter.

LINE SIDE POWER MUST BE SWITCHED OFF PRIOR TO REPLACEMENT OF FAN.



Warning:

Power electronic devices like motor drives contain large capacitors which may retain perilous charges for a period of time. Before opening the cabinet or device, disconnect the supply power and let ample time elapse (> 1 minute) for the capacitors to discharge to safe levels. Use a meter to check terminal voltages before touching or handling!

Maintenance considerations:

Schaffner harmonics filters are equipped with long life components that ensure a satisfactory function for many years under normal operating conditions. Any operation under extreme conditions such as over-temperatures, overvoltage situations, polluted environments etc. reduces the life expectancy.

Under normal operating conditions (ambient temp at 25°C) and with the filter permanently charged at full load, the fan(s) will typically have 50% duty cycle. This translates roughly to a **10 year** maintenance-free life time.

Nevertheless, it is recommended to check the functionality at least in a **2 year interval**, when a 'normal 100% load' situation is given. More severe operating conditions may require shorter service intervals.

Indications for required fan replacement:	- increased audible noise coming from the fan - after 50,000 hours fan ON state.
---	---

Power capacitor damage may be caused by severe abnormal supply voltage peaks (i.e. lightning – depending upon system protection), but may only be recognizable through the measurement of line side harmonics distortion. This may be indicated with a modern energy meter or by regular checkup with a distortion analyzer. According to the above considerations, a **2 year inspection interval** is advisable. An inspection should as well be performed after extreme overvoltage situations.

Field replacement of power capacitors is possible, but must be executed by trained Schaffner personnel.

Indications for required capacitor replacement:	- performance loss (THID out of spec) - visible capacitor damage
---	---

Fan specifications:

Supply voltage:	24VDC
Power:	max. 7W
Size 1*:	92x92x25mm, fixation holes 82.5x82.5mm, Ø4.3mm
Size 2*:	120x120x25mm, fixation holes 105x105mm, Ø4.3mm
Air flow (size 1):	min. 70CFM (cubic feet per minute / 1 CFM = 1.7m ³ /h)
Air flow (size 2):	min. 110CFM
Connection:	min. 150mm cable length, TYCO MTA-100 plug, 2 poles (pin 1 = +24VDC)
Recommended types (Size 1):	SUNON PE92252V1-0000-A99 NMB-MAT 3610KL-05W-B50
Recommended types (Size 2):	SUNON PMD2412PTB3-A NMB-MAT 4710KL-05W-B50

- * Size 1: FN 341x-10-44, FN 341x-13-44, FN 341x-8-44, FN 341x-11-44
Size 2: all other filters

Fan replacement instructions:

- 1 Disconnect line side power.**
Consult your local safety instructions. 
- 2 Unscrew fan plate on bottom side of filter.
- 3 Pull out fan connector plug.
- 4 Disassemble fan from plate (4 bolts).
- 5 Mount a new fan with appropriate plug (isolation tube and plug of old fan may be used again; appropriate tool for IDC connection needed). Pay attention to the polarity of the plug.
- 6 Connect fan to plug socket, re-assemble fan plate.



Step 2

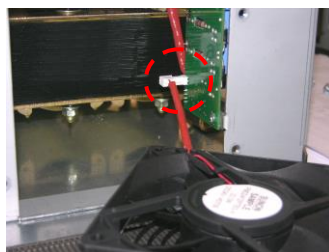

Step 3

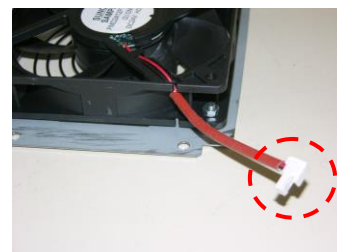

Steps 4, 5

8. Special considerations

8.1 Over-temperature switch and load disconnect

ECOsine® harmonic filters provide advanced safety monitoring:

- two temperature detection levels for each inductive component (fan activation level, over-temperature indication level)
- monitoring of temperature sensor impedance (too low – short – and too high – open – impedance trigger monitor switch)
- fan operation monitoring (too low fan current or fan supply voltage are recognized and trigger monitor switch).

All these alarm indications request adequate reaction in order to prevent possible system damage (i.e. cable or cabinet overheating). Either the cabinet safety monitoring unit will make use of the alarm switch, or the switch can directly control a stop function of a connected motor drive (refer to drive manual for applicability).

Technical data of monitor switch:

Error status:	Switch open
Switching power:	max. 3A/250VAC or 30VDC min. 10mA/5V
Technology:	Mechanical switch (relay, potential-free)
Safety:	UL 508

Note: The described applications of the monitor switch are proposals. Please respect local and national safety prescriptions.

Note: Open switch state is identical to non-powered state, thus safety monitoring unit must override monitoring signal during power-on or restart.

8.2 Trap circuit disconnect

The trap circuit disconnect feature is built-in for the purpose of reducing the capacitive current during low load operation, if needed. With permanently connected trap circuit, $\cos(\phi)$ vs. load shows following characteristics:

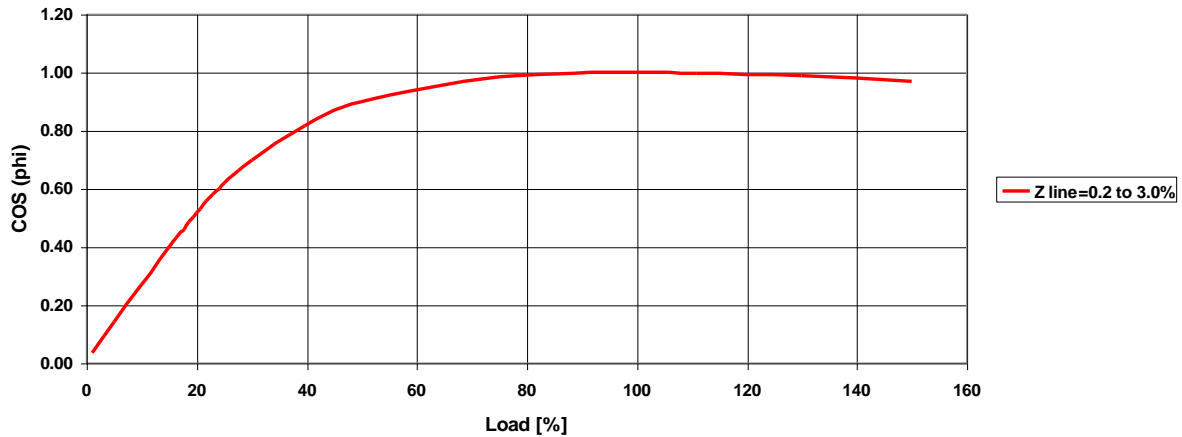

When the trap circuit is disconnected, $\cos(\phi)$ returns to ~ 0.98 . At the same time, the THID will increase. This may be negligible, since absolute values are low due to reduced load power. Required external components (not part of ECOSine® filter) or system functions for fully automated capacitive current control:

- motor load (power factor) monitoring device
- capacitor contactor

A reduced load system status may be available as system controller output signal. In this case, only adequate driving of capacitor contactor has to be assured.

Note: It is necessary to take into account overall concept of power factor correction. A system PFC correction unit with large capacitor banks may become obsolete or massively reduced, when harmonic filters are installed. In such cases it may not be necessary to install trap circuit disconnect functions.

Recommended settings:

Schaffner recommends to engage and disengage the trap circuit disconnect at following load levels:

Trap circuit status	Proposed load level
Dis-connect	When load level drops under 10-15%
Connect	When load level rises above 20-25%

9. Application examples

9.1 Harmonics mitigation on an individual motor drive

Problem: A 5.5kW motor drive with diode rectifier is used in the well head control system of a small scale oil exploration site. The drive is controlling the motor of a submersible pump down in the well. It is designed to run close to full load for the most part. The well head control unit has to meet IEEE Std 519-2014. The existing harmonic spectrum is significantly above acceptable limits.

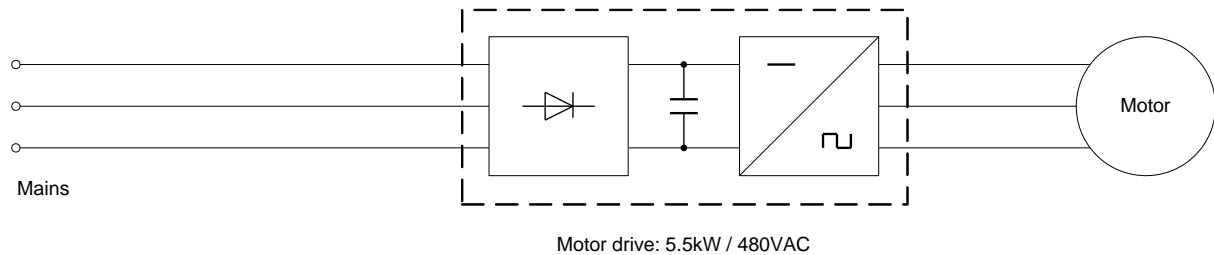

Measurements without filter:

Current:

$I_{in} = 11A_{rms}$ (for power 5.5kW)
 THID = 92% ($R_{sce} = 150$)
 PWHD = 37%

Voltage:

$U_{in} = 480V_{rms}$ (phase-phase)
 THVD = 4.4% (for $I_{sc}/I_L = 150$)

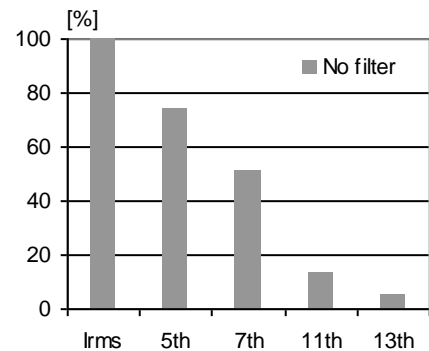
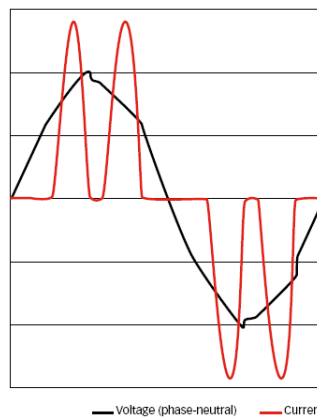

Solution: ECOSine® FN 3410-10-44 is the appropriate harmonic filter to match both the system specifications and the load rating. Ideally, the filter is installed close to the motor drive, potentially next to it on the back wall of the cabinet.

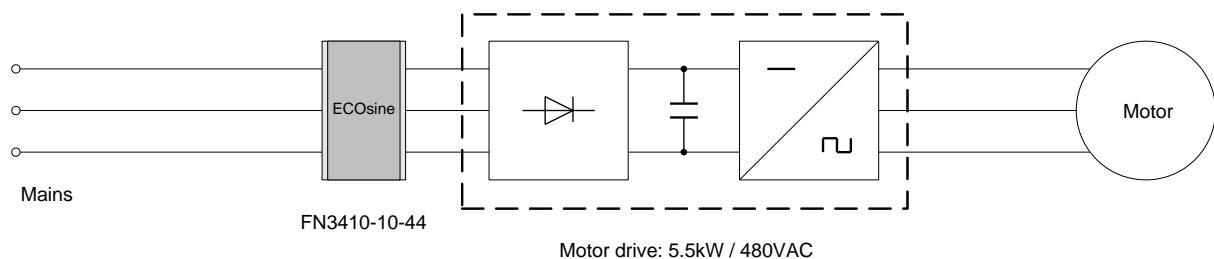

Measurements with filter:

Current:

$I_{in} = 7.5A_{rms}$ (for power 5.5kW)
 THID = 4.0% ($R_{sce} = 150$)
 PWHD = 5.2%

Voltage:

$U_{in} = 480V_{rms}$ (phase-phase)
 THVD = 0.12% (for $I_{sc}/I_L = 150$)

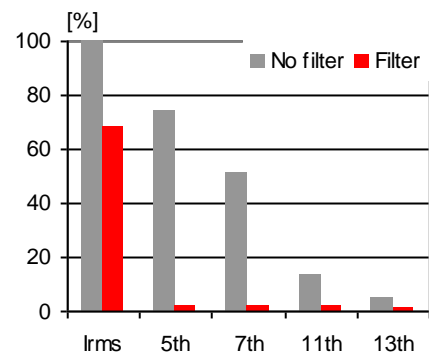
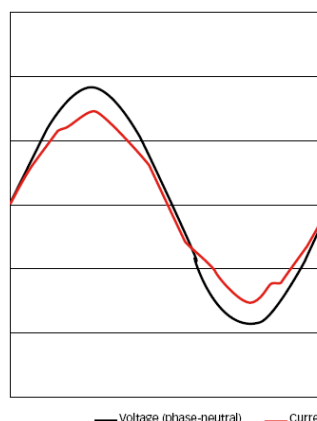

9.2 Harmonics mitigation in applications with multiple loads in parallel

Problem: An office building is operating 3 HVAC systems in parallel, involving drives with diode rectifiers and motors of different power rating. On average, the drives are running at 85% of rated power. The resulting harmonic distortion is causing crashes of the in-house IT infrastructure. In addition, the entire factory does not meet the IEEE Std 519 requirements at the point of common coupling PCC (TDD 102.5%). The use of an active harmonic filter at the main building bus has already been evaluated, but it is out of the question for cost reasons. The project manager has to determine the best yet affordable solution.

Potential solution 1: The first attempt of the project manager is the installation of 1 ECOsine® harmonic filter type FN 3410-180-40 (400V, 50Hz, 90kW) upstream of the 100kW drive, loaded with 85%.

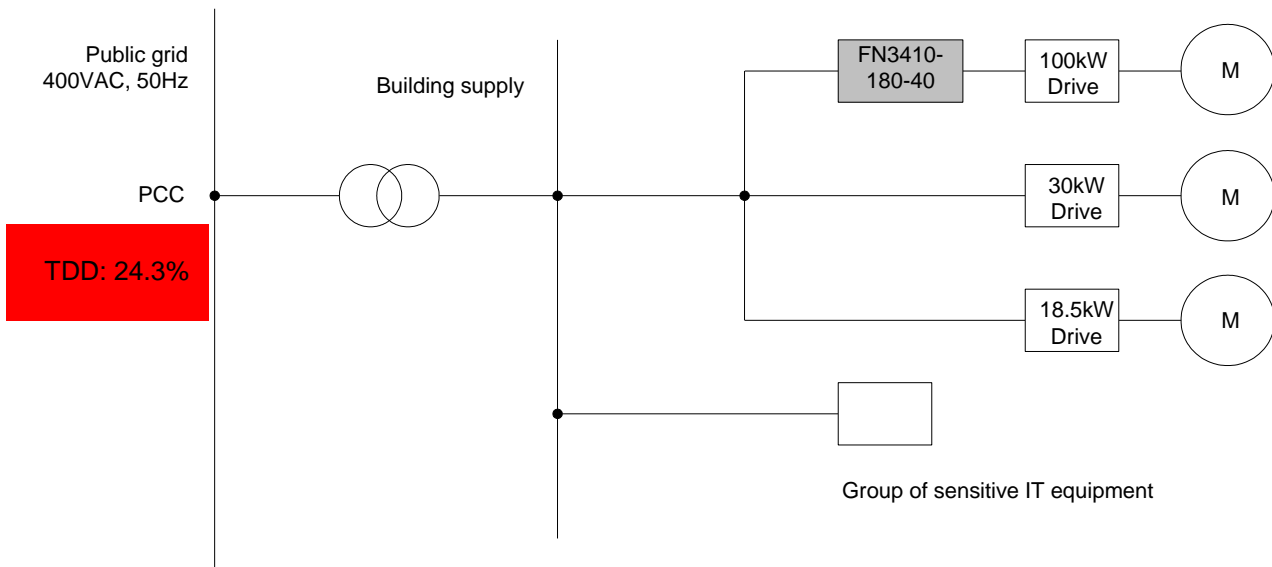

Trying to utilize the harmonic filter at the biggest non-linear load is a good idea, but not sufficient in this case. The TDD at the PCC after the installation of FN 3410-180-40 is 24.3%. System loading parameters ask for a TDD of max. 8% according to IEEE Std 519.

Potential solution 2: In order to overcome the problem above, additional filters upstream of the lower power drives can be installed. A good choice is FN 3410-60-34 (400V, 50Hz, 30kW) for the 30kW drive and FN 3410-32-33 (400V, 50Hz, 15kW) for the 18.5kW drive (both loaded 85%).

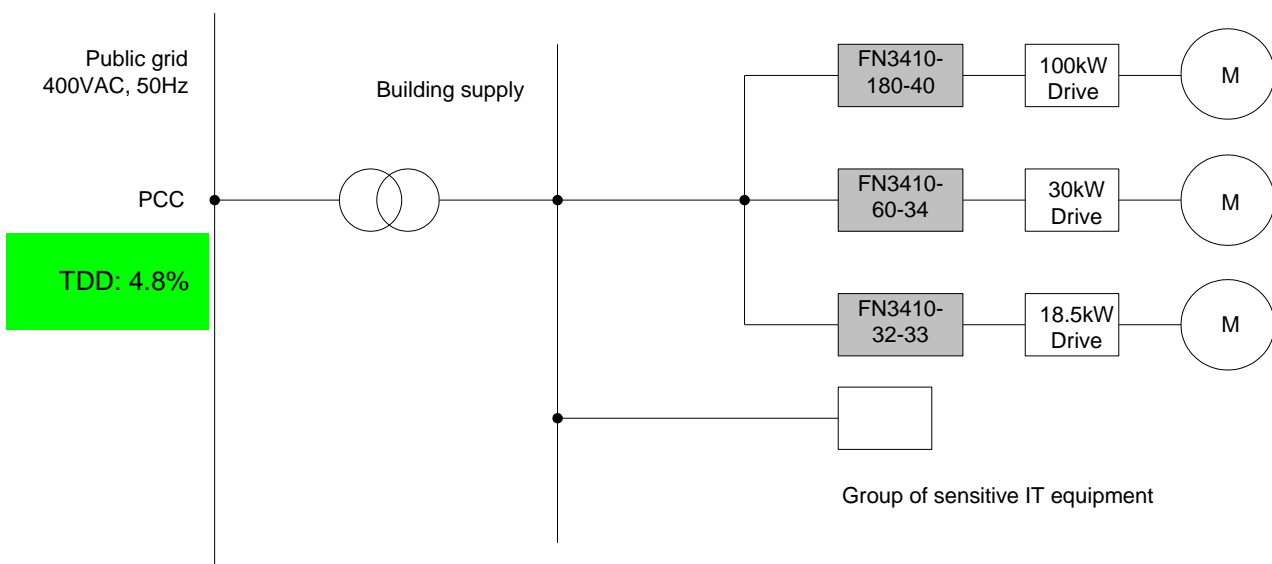

Adding these harmonic filters results in 4.8% TDD at the PCC, and thus IEEE Std 519 is fulfilled. However, adding a total of 3 filters to the system may not be the most economic solution, so the project manager considers yet another option.

Potential solution 3: Instead of adding a filter to each drive, 1 higher power ECOsine® harmonic filter with the following ratings is added: FN 3410-260-99 (400V, 50Hz, 132kW). The total load real power of the 3 drives running in parallel at 85% is 126kW.

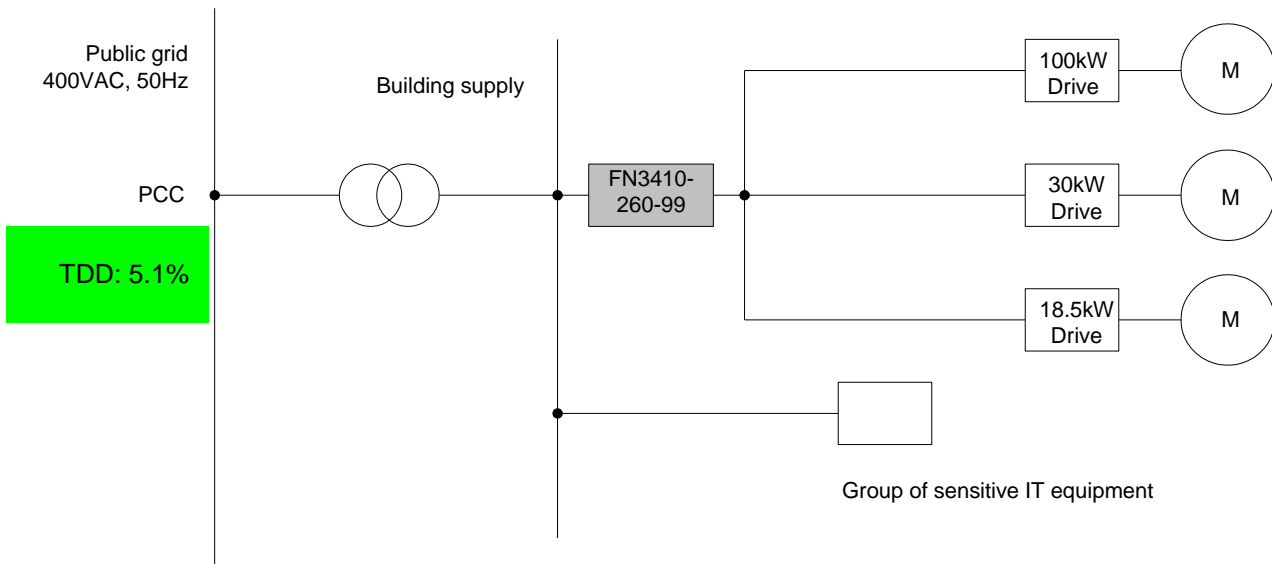

The measured result at the PCC after the implementation of above measures is now a TDD of 5.1%, and thus the building is still well within the IEEE Std 519 requirements. An economic and technical analysis including filter price and installation time results in the conclusion that solution number 3 will be chosen for this particular case.

10. Troubleshooting

Schaffner ECOsine® harmonic filters are high quality products and have undergone rigorous testing and qualification procedures. Every unit runs through a 100% test in our ISO 9001:2000 factories. There are no troubles to be expected if the filter is installed, operated, and maintained as described in this document.

In the unlikely event of a problem, please contact your local Schaffner partner for assistance.

11. FAQ – Frequently asked questions

Q: Why are ECOsine® harmonic filters CE-marked, but Schaffner EMI filters are not?

A: EMI filters and other passive components must not be CE-marked according to the low-voltage directive because they are not sold to the public as an individual device with an independent function. They are usually part of an equipment, which in turn has to be CE-marked as a whole. This is different with e.g. a transformer or a harmonic filter. ECOsine® can be sold as an individual aftermarket product that will not necessarily be built into another CE-conform piece of equipment. As a “stand-alone unit”, it must be CE-marked in order to be distributed throughout Europe.

Q: Can ECOsine® filters be used for a single-phase load or just be connected to two phases?

A: This mode of operation is not possible. ECOsine™ filters are optimized for balanced three-phase power systems with six-pulse rectifier front ends and their performance depends upon voltage distortion and phase unbalance. Schaffner is experienced in custom harmonic filter design and can potentially come up with a single-phase solution to your requirement.

Q: How are ECOsine® harmonic filters contributing to financial savings? Are they reducing my electricity bill?

A: ECOsine™ harmonic filters help to save long term system operating cost and help to avoid expensive system/production downtime. There are two different aspects to answer this question:

1. Most likely, the installation of ECOsine® filters will not result in a lower electricity bill. ECOsine® harmonic filters substantially reduce reactive current and thus reactive power in the system. However, most utility companies invoice only the consumption of real power, which will not be changed with the installation of ECOsine™. Some utilities may issue penalties for consumers with low power factor (usually <0.9). Low power factor can be caused by phase shift of the fundamental current (low cos phi) and/or by harmonics of the current (high THID) as it is described by the following formula:

$$PF = \frac{\cos \varphi}{\sqrt{1 + THD^2}}$$

For nonlinear loads (like six-pulse rectifiers) value of cos phi is high (close to 1) and the main reason for a reduced power factor is a high value of THID. The installation of ECOsine® filters would increase the power factor and help to avoid utility penalties, i.e. get into a less expensive rate class. These penalty schemes are different from country to country and from utility company to utility company.

2. Electric systems with significant non-linear loads have high levels of harmonic current distortion and consequently also bad voltage quality. Both can have significant negative effects, such as:

Transformers

- Increased audible noise
- Increase in copper losses (due to current harmonics)
- Increase in iron losses (due to voltage harmonics)

Power installation with capacitive power factor compensators

- Risk of resonance and resulting damage of capacitor banks

Power cables

- Increased heating
 - Risk of insulation failure if involved in system resonance
-

Motors and Generators

- Increased heating due to iron and copper losses at the harmonic frequencies (performance reduced to 90%)
- Higher audible noise
- Refusal to start smoothly (cogging)
- Very high slip in induction motors (crawling)
- Potential of mechanical oscillations in a turbine-generator or motor-load systems
- Pulsating or reduced torques

Capacitors

- Increased heating and voltage stress
- Reduced capacitors life

Electronic Equipment

- Wrong operation of equipment dependent upon accurate determination of the line voltage wave shape (e.g. zero crossing)
- Problems caused by transmission of ac supply harmonics (via power supply or magnetic coupling) into equipment components
- Erratic (sometimes subtle) malfunctions of computers, programmable controllers, medical instruments etc. (in some cases, having very serious consequences)

Metering (watt-hour meters)

- Possible erroneous operation with both positive and negative errors (distortion must be severe >20%)

Switchgear and Relaying

- Increased heating and thus reduced steady-state current carrying capability
- Fuses suffer derating
- Complete definition of relay response impossible
- Older circuit breakers (responding to peak currents) may cause nuisance tripping

Communication Equipment

- Telephone interferences (audible harmonic frequencies)

ECOsine® harmonic filters substantially reduce harmonic currents to (THID <5% at any load condition) and therefore basically convert a non-linear load into a linear load. This fact eliminates the risk for most of the above problems. Lower harmonic currents help to relieve the entire electrical installation from excessive loading and heating, allow more consumers to be powered by the same (existing) installation, and help to postpone expensive electrical system upgrades when retrofitting additional non-linear consumers. ECOsine™ filters also reduce the risk of harmonics-related system downtimes which can have tremendous financial consequences e.g. in a semiconductor manufacturing line or a banking center. Last but not least, lower harmonic currents cause less harmonic voltages when flowing through system impedances, so other sensitive consumers (e.g. medical devices) connected to the same branch of the electrical system are not compromised in their functionality.

→ So in essence, the annual savings enabled by ECOsine™ harmonic filters are first and foremost the avoided potential expenses thanks to lack of harmonics.

-
- Q:** How much cooling air capacity should be planned for the integration of ECOsine™ filters into a cabinet?
- A:** This value, defined as CFM (cubic feet per minute; 1CFM = 1.7m³/h) depends upon filter model and power rating. Please refer to the following table:

FN 3410 / FN 3411 (400-500V/50Hz)	FN 3412 / FN 3413 (480V/60Hz)	Air capacity needed
-10, -13	-8, -11	70CFM
-16 -24, -32, -38 -45, -60 -75, -90, -110	-15, -21 -28, -35, -41 -53, -65 -80, -105, -130	110CFM
-150, -180, -210	-160, -190	220CFM
		330CFM
-260, -320	-240, -310	440CFM

12. Custom design input form

There may be occasions where ECOsine® standard filters are not suitable for the job at hand. Schaffner is very experienced in the design and manufacturing of custom filters based on the existing modular ECOsine® platform and can potentially come up with an alternative design proposal for you.

Custom harmonic filters include (but are not limited to) solutions for higher power ratings, higher voltage ratings, different performance levels, or special mechanical designs.

Please use the following table to gather essential technical information prior to contacting your local Schaffner partner.

Application incl. power system:		
Types of non-linear loads:		
Types of rectifiers involved:		
System block schematic:		
Current harmonic spectrum:		
Required harmonics reduction (THID, TDD, standard):		
Expected total load real power:		[kW], [HP]
Expected total input current:		[A]
System voltage:		[VAC]
System frequency:		[Hz]
Efficiency:		[%]
Overload capability:		[%]
Max. capacitive current:		[%], [A]
Ambient temperature:		[°C]
Expected life time:		[h]
Mechanical requirements:		
Terminals:		
Safety approvals:		
Monitoring functionality:		
Other special requirements:		

Appendix I: International standards

The use of non-linear loads with six-pulse rectifiers has grown rapidly in recent years, to the point where this type of load represents more than 50% of western world power system load. Harmonic currents and the resulting voltage distortions can have devastating effects on power distribution systems and connected equipment. Therefore, national and international standards for harmonic distortions (and other Power Quality problems) are needed.

In the following, a brief overview of some important international standards/recommendations are provided. For full details, please obtain the required standards directly from IEEE, IEC, and other organizations.

I. Engineering recommendation G5/4-1

Definitions:

Non-linear load or equipment	A load or equipment that draws a non-sinusoidal current when energized by a sinusoidal voltage.
Aggregate load	Non-linear load equal to the sum of the individual non-linear equipment ratings.
Fault level	A value expressed in MVA of the symmetrical short-circuit power at a point in the supply system. It is defined as the product of the symmetrical short-circuit current (I_{sc}) and the nominal system voltage (U_{ph-ph} or U_{ph-n}): $F = I_{sc} \cdot U_{ph-ph} \cdot \sqrt{3} = I_{sc} \cdot U_{ph-n} \cdot 3$
Harmonic current (I_h)	The RMS value of a harmonic current, of order h , expressed in amperes.
Harmonic distortion	The cyclic departure of a waveform from the sinusoidal shape. This can be described by the addition of one or more harmonics to the fundamental.
Point of common coupling (PCC)	The point in the public supply system, electrically nearest to a customer's installation, at which other customers' loads are, or may be, connected.
Total harmonic voltage distortion (THD)	$THD = \sqrt{\frac{\sum_{h=2}^{h=50} V_h^2}{V_1^2}}$

G5/4-1 planning levels for harmonic voltages:

Table 2: Planning Levels for Harmonic Voltages in 400V Systems

Odd harmonics (Non-multiple of 3)		Odd harmonics (Multiple of 3)		Even harmonics	
Order 'h'	Harmonic voltage (%)	Order 'h'	Harmonic voltage (%)	Order 'h'	Harmonic voltage (%)
5	4.0	3	4.0	2	1.6
7	4.0	9	1.2	4	1.0
11	3.0	15	0.3	6	0.5
13	2.5	21	0.2	8	0.4
17	1.6	>21	0.2	10	0.4
19	1.2			12	0.2
23	1.2			>12	0.2
25	0.7				
>25	$0.2 + 0.5^{(25/h)}$				

The Total Harmonic Distortion (THD) level is 5%.

G5/4-1 current harmonic limits for loads rated >16A per phase:

Table 7: Stage 1 Maximum Permissible Harmonic Current Emissions in Amperes RMS for Aggregate Loads and Equipment Rated >16A per phase

Harmonic order, h	Emission current, I _h	Harmonic order, h	Emission current, I _h	Harmonic order, h	Emission current, I _h	Harmonic order, h	Emission current, I _h
2	28.9	15	1.4	28	1.0	41	1.8
3	48.1	16	1.8	29	3.1	42	0.3
4	9.0	17	13.6	30	0.5	43	1.6
5	28.9	18	0.8	31	2.8	44	0.7
6	3.0	19	9.1	32	0.9	45	0.3
7	41.2	20	1.4	33	0.4	46	0.6
8	7.2	21	0.7	34	0.8	47	1.4
9	9.6	22	1.3	35	2.3	48	0.3
10	5.8	23	7.5	36	0.4	49	1.3
11	39.4	24	0.6	37	2.1	50	0.6
12	1.2	25	4.0	38	0.8		
13	27.8	26	1.1	39	0.4		
14	2.1	27	0.5	40	0.7		

These limits are based on a typical fault level of 10 MVA; see Table 9 and Application Guide ETR 122.

II. International standard EN 61000-3-12

This standard applies to equipment intended to be connected to low-voltage systems interfacing with the public supply at the low-voltage level. It does not apply to equipment intended to be connected only to private low-voltage systems interfacing with the public supply only at the medium- or high-voltage level.

Definitions:

Total harmonic distortion (THD) Ratio of the r.m.s. value of the harmonics (harmonic currents I_n of the order n) to the r.m.s. value of the fundamental:

$$THD = \frac{\sqrt{\sum_{n=2}^{40} I_n^2}}{I_1}$$

Partial weighted harmonic distortion (PWHD) Ratio of the r.m.s. value of a selected group of higher order harmonics (in this International Standard beginning from the fourteenth harmonic), weighted with the harmonic order n , to the r.m.s. value of the fundamental:

$$PWHD = \sqrt{\sum_{n=14}^{40} n \cdot \left(\frac{I_n}{I_1}\right)^2}$$

Reference fundamental current (I_1) r.m.s. value of the fundamental component of the rated line current I_{equ} of the equipment. The reference fundamental current I_1 , shall be either measured, or calculated as follows:

$$I_1 = \frac{I_{equ}}{\sqrt{1 + THD^2}}$$

Total harmonic current (THC) The total r.m.s. value of the harmonic current components of orders 2 to 40:

$$THC = \sqrt{\sum_{n=2}^{40} I_n^2}$$

Point of common coupling (PCC) The point in the public system which is closest to the customer concerned, and to which other customers are, or may be, connected.

Short circuit power (S_{sc}) Value of the three-phase short-circuit power calculated from the nominal interphase system voltage $U_{nominal}$ and the line impedance Z of the system at the PCC: $S_{sc} = U_{nom}^2 / Z$
 where Z is the system impedance at the power frequency.

Rated apparent power of the equipment (S_{equ}) Value calculated from the rated line current I_{equ} of the piece of equipment stated by: $S_{equ} = 3 \cdot U_i \cdot I_{equ}$

Short circuit ratio (R_{sce}) Characteristic value of a piece of equipment defined as follows:

$$R_{sce} = S_{sc} / S_{equ}$$

EN 61000-3-12 current harmonic limits:

Table 3 – Current emission limits for balanced three-phase equipment

Minimal R_{sce}	Admissible individual harmonic current I_n/I_1 ^a %				Admissible harmonic current distortion factors %	
	I_5	I_7	I_{11}	I_{13}	<i>THD</i>	<i>PWHD</i>
33	10,7	7,2	3,1	2	13	22
66	14	9	5	3	16	25
120	19	12	7	4	22	28
250	31	20	12	7	37	38
≥350	40	25	15	10	48	46

NOTE 1 The relative values of even harmonics up to order 12 must not exceed 16/n %. Even harmonics above order 12 are taken into account in *THD* and *PWHD* in the same way as odd order harmonics.

NOTE 2 Linear interpolation between successive R_{sce} values is permitted. See also Annex B.

^a I_1 = reference fundamental current; I_n = harmonic current component.

Table 4 – Current emission limits for balanced three-phase equipment under specified conditions

Minimal R_{sce}	Admissible individual harmonic current I_n/I_1 ^a %				Admissible harmonic current distortion factors %	
	I_5	I_7	I_{11}	I_{13}	<i>THD</i>	<i>PWHD</i>
33	10,7	7,2	3,1	2	13	22
≥120	40	25	15	10	48	46

NOTE 1 The relative values of even harmonics up to order 12 must not exceed 16/n %. Even harmonics above order 12 are taken into account in *THD* and *PWHD* in the same way as odd order harmonics.

NOTE 2 Linear interpolation between successive R_{sce} values is permitted. See also Annex B

^a I_1 = reference fundamental current; I_n = harmonic current component.

Conditions to use Table 4:

1. The phase angle of the 5th harmonic current related to the fundamental phase voltage is in the range of 90° to 150°.

Note: This condition is normally fulfilled by equipment with an uncontrolled rectifier bridge and capacitive filter, including a 3% AC or 4% DC reactor.
2. The design of the equipment is such that the phase angle of the 5th harmonic current has no preferential value over time and can take any value in the whole interval (0°...360°).

Note: This condition is normally fulfilled by converters with fully controlled thyristor bridges.
3. The 5th and 7th harmonic currents are each less than 5% of the reference fundamental current.

Interpolation of current harmonic limits:

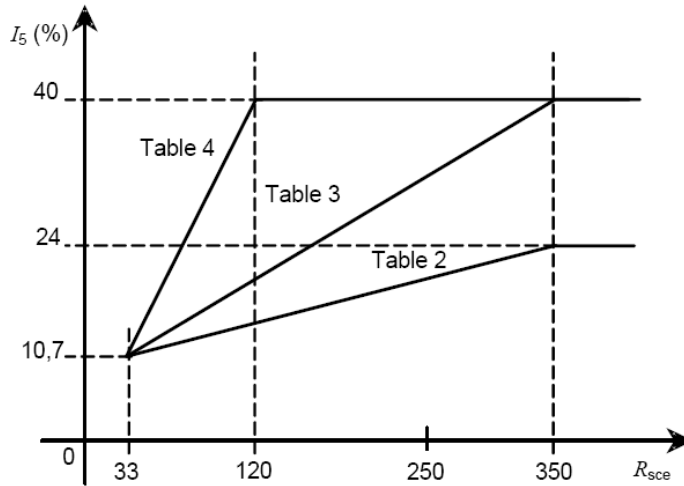

Figure A.1 – Limits of the 5th harmonic current as functions of R_{sce}

Product documentation according to EN 61000-3-12:

For equipment complying with the harmonic current emission limits corresponding to $R_{sce} = 33$, the manufacturer shall state in his instruction manual or literature:

"Equipment complying with IEC 61000-3-12"

For equipment not complying with the harmonic currents emission limits corresponding to $R_{sce} = 33$, the manufacturer shall:

- determine the minimum value of R_{sce} for which the limits given in Table 3 or 4 are not exceeded,
- declare the value of the short-circuit power S_{sc} corresponding to this minimal value of R_{sce} in the equipment instruction manual
- and instruct the user to determine, in consultation with the distribution network operator, that the equipment is connected only to a supply of that S_{sc} value or more. For that purpose, the statement in the instruction manual shall be:

"This equipment complies with IEC 61000-3-12 provided that the short-circuit power S_{sc} is greater than or equal to xx at the interface point between the user's supply and the public system. It is the responsibility of the installer or user of the equipment to ensure, by consultation with the distribution network operator if necessary, that the equipment is connected only to a supply with a short-circuit power S_{sc} greater than or equal to xx."

Where xx is the value of S_{sc} corresponding to the minimum value of R_{sce} for which the limits given in Table 3 or 4 are not exceeded.

III. IEEE Std 519-1992

Table 10-3 lists the harmonic current limits based on the size of the load with respect to the size of the power system to which the load is connected. The ratio I_{sc}/I_L is the ratio of the short-circuit available at the point of common coupling (PCC), to the maximum fundamental load current.

IEEE Std 519-1992 also introduces the total demand distortion (TDD), the harmonic current distortion in % of maximum demand load current (15 or 30min demand).

The limits listed in Tables 10-3 (respectively, Table 2 pag 7 in the last release IEEE-519/2014, the table is unchanged), should be used as system design values for the worst case for normal operation (conditions lasting longer than one hour). For shorter periods, during start-ups or unusual conditions, the limits may be exceeded by 50%.

Table 10-3: current distortion limits for general distribution systems (120V through 69000V):

Maximum Harmonic Current Distortion in Percent of I_L						
Individual Harmonic Order (Odd Harmonics)						
I_{sc}/I_L	<11	11≤h<17	17≤h<23	23≤h<35	35≤h	TDD
<20*	4.0	2.0	1.5	0.6	0.3	5.0
20<50	7.0	3.5	2.5	1.0	0.5	8.0
50<100	10.0	4.5	4.0	1.5	0.7	12.0
100<1000	12.0	5.5	5.0	2.0	1.0	15.0
>1000	15.0	7.0	6.0	2.5	1.4	20.0

Even harmonics are limited to 25% of the odd harmonic limits above.

Current distortions that result in a dc offset, e.g., half-wave converters, are not allowed.

* All power generation equipment is limited to these values of current distortion, regardless of actual I_{sc}/I_L .

where
 I_{sc} = maximum short-circuit current at PCC.
 I_L = maximum demand load current (fundamental frequency component) at PCC.

Other standards:

ECOsine® harmonic filters are perfectly suitable to fulfill the most stringent requirements of IEEE Std 519-1992 or EN 61000-3-12. They also fulfill the requirements of other standards, like e.g. EN 12015 for elevators and escalators. However, because of different/relaxed limits, simpler filters may be sufficient for the job. Schaffner has already designed many engineered harmonic filters for relaxed requirements and may be able to quickly offer you a custom product that perfectly matches the requirements of an application.

Appendix II: Declaration of conformity

Declaration of Conformity



manufacturer: Schaffner EMV AG
Nordstrasse 11
CH-4542 Luterbach
Switzerland

declares, under the sole responsibility, that the following

products: ECOsine™ FN3410 range
ECOsine™ FN3411 range
ECOsine™ FN3412 range
ECOsine™ FN3413 range

options: all

are in conformity with the following directives and standards:

directives: Low voltage directive 2006/95/EC
EMC directive 2004/108/EC

standards: EN 50178: Electronic equipment for use in power installations
EN 61000-6-2: EMC immunity for industrial environments

ECOsine™ FN3410 to FN3413 filters are passive harmonic filters designed for the operation on the input (grid) side of power electronic equipment with 6-pulse diode (FN3410, FN3412) or SCR (FN3411, FN3413) rectifier front ends in balanced three-phase power systems, like typically used in AC or DC motor drives and high power DC supplies.

The installation instructions are integrated part of the product. The product shall exclusively be used in the above-mentioned applications according to the installation instruction.

The validity of this declaration expires, if the products are modified or improperly applied.

We certify the compliance of the products and options with the mentioned directives and standards.

Luterbach, 17.09.2009

Schaffner EMV AG

Alexander Hagemann
CEO

Fabian Beck,
VP Research & Development