

MATERIAL AND FINISH:

Insulator: PC (Polycarbonate), color black, UL-94V-0

Contacts: Brass, Tin plated

ELECTRICAL SPECIFICATIONS:

Rated current: 2.5A

Rated voltage: 250VAC



RoHS COMPLIANT

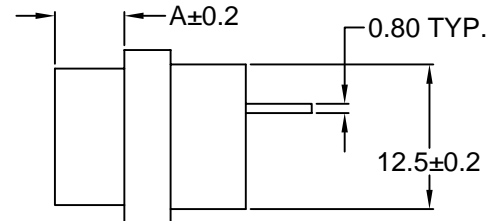
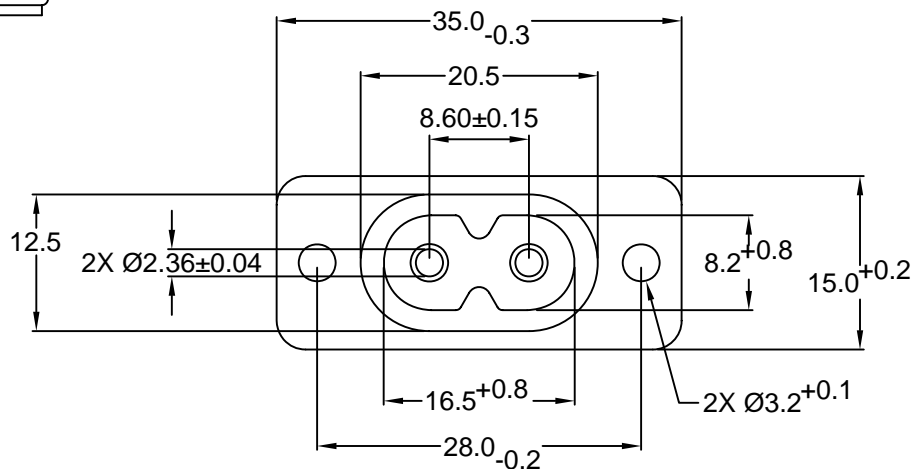

ORDERING CODE:

4251-112_1

- 1) 1 = 0.04 (1.0mm)
- 2 = 0.24 (6.0mm)

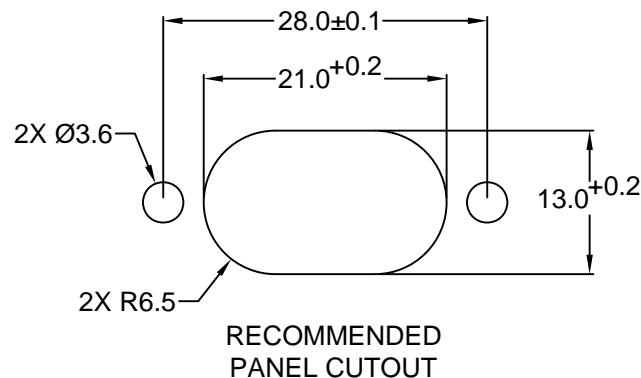
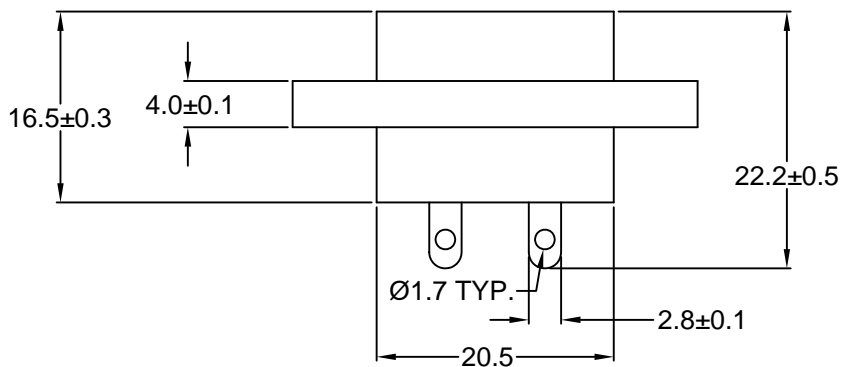

RECOMMENDED PANEL CUTOUT

REV	DATE	CHANGE	CHKG	CHECK	APPR

TOLERANCE UNLESS OTHERWISE SPECIFIED	
X	± 1
X.X	± 0.4
X.XX	± 0.20

Power Dynamics, Inc.

Phone: 973 560-0019 Whippany, New Jersey Fax: 973 560-0076

PART: MINIATURE IEC 60320 C8 APPL. INLET; 1.0mm - 6.0mm SIDE FLANGE MOUNT, SOLDER TERMINALS

P/N	A	DRAWN BY	GQ	DATE:
42R51-1121	1.0			11/14/01
42R51-1122	6.0	CHECK BY	TD	DATE: 11/16/01
		APPR BY	PB	DATE: 11/16/01

PART #: 42R51-112X		SHEET 1 of 1
SIZE: A	ALL DIMENSIONS FOR REFERENCE ONLY DIMENSIONS ARE IN MILLIMETERS	REV:
SCALE: NTS		