

REV.	DESCRIPTION	DATE	DR.	APVD.
A	ISSUED	04/23/2019	YS	DS

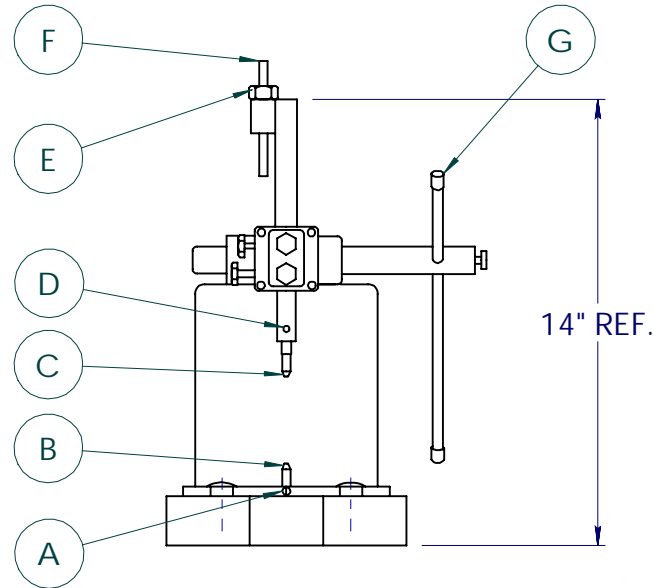
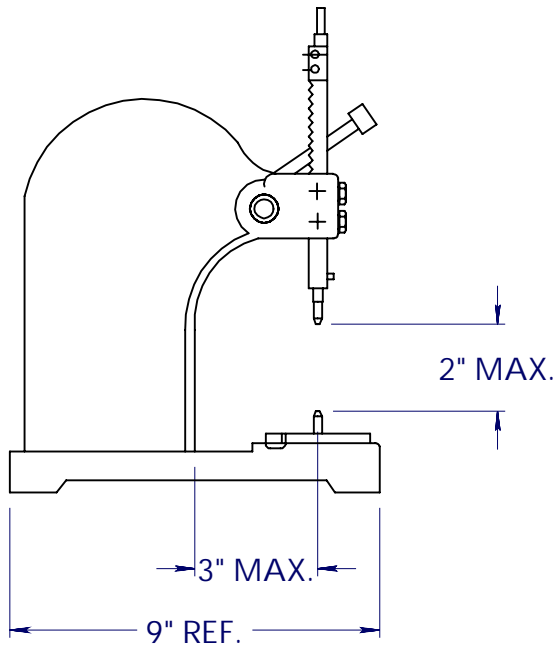

USER MANUAL:

1. LOOSEN SET SCREW (A) AND INSERT ANVIL (B)
2. TIGHTEN SET SCREW (A)
3. LOOSET SET SCREW (D) AND INSERT PUNCH (C)
4. TIGHTEN SET SCREW (D)
5. ADJUST STOP (F) WITH NUT (E)
6. PLACE PIECE TO BE SWAGED IN ANVIL (B) (SWAGE END UP)
7. PLACE BOARD ON PIECE TO BE SWAGED SUCH THAT SWAGE END PROTRUDES THROUGH HOLE IN BOARD
8. PULL ARM (G) TO LOWER PUNCH (C) TO SWAGE

UNLESS OTHERWISE SPECIFIED:

DIMENSIONS ARE IN INCHES

TOLERANCES:

THREE PLACE DECIMAL ±0.010
FRACTIONAL ±1/64

PROPRIETARY AND CONFIDENTIAL

THE INFORMATION CONTAINED IN THIS DRAWING IS THE SOLE PROPERTY OF CONCORD ELECTRONICS INC. ANY REPRODUCTION IN PART OR AS A WHOLE WITHOUT THE WRITTEN PERMISSION OF CONCORD ELECTRONIC INC. IS PROHIBITED.



TITLE:

MANUAL OPERATED
ARBOR PRESS

DWG. NO.

TM1

REV

A



WEIGHT: 21 LBS

SCALE: NTS